

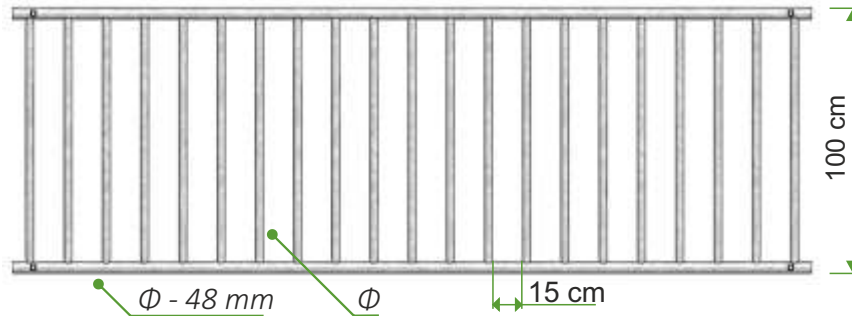

CALF DIVIDER

PKC 1 - 1, PKC 1 - 2



PKC 2 - 1, PKC 2 - 2

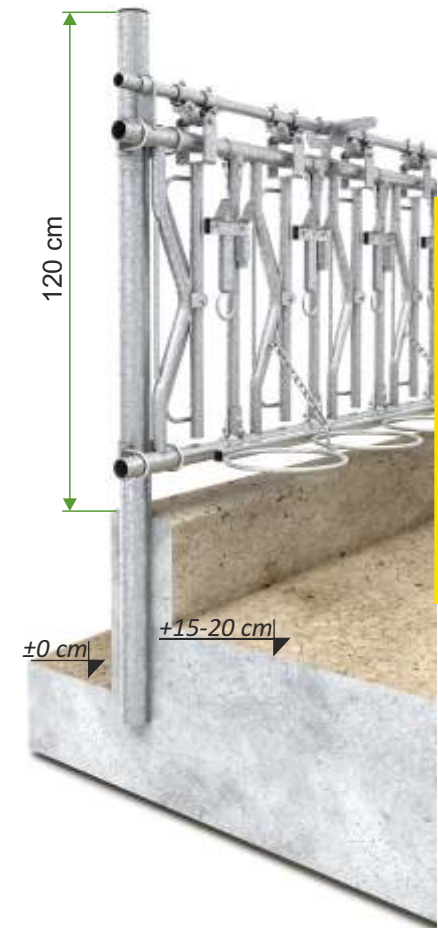
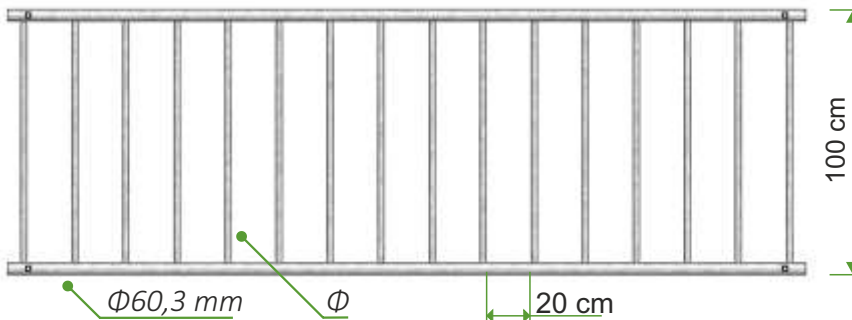

- | | | |
|---|---------------------|--|
| 1 | W10-14-03 | Calf divider PKC 1 - 1 HDG (Φ 26,9 mm) |
| 2 | W10-14-06 | Calf divider PKC 1 - 2 HDG (Φ 33,7 mm) |
| 3 | W10-14-32-50 | Calf pen gate FKC 1 - 1 HDG (Φ 26,9 mm) |
| 4 | W10-14-35-50 | Calf pen gate FKC 1 - 2 HDG (Φ 33,7 mm) |
| 5 | W10-14-12 | Calf divider PKC 2 - 1 HDG (Φ 26,9 mm) |
| 6 | W10-14-15 | Calf divider PKC 2 - 2 HDG (Φ 33,7 mm) |
| 7 | W10-14-44-50 | Calf pen gate FKC 2 - 2 HDG (Φ 26,9 mm) |
| 8 | W10-14-47-50 | Calf pen gate FKC 2 - 3 HDG (Φ 33,7 mm) |

m
m
pcs
pcs
m
m
pcs
pcs

HDG - anti-corrosion protection - hot-dip galvanized.



DIVIDERS

DIVIDER PST - 1 , PST - 1-1



- 1 **W10-05-00-11** Divider PST-1 HDG (Φ 60,3 mm) pcs
- 2 **W10-05-00-13** Divider PST-1-1 HDG (Φ 48,3 mm) pcs

DIVIDER PST - 2 , PST - 2-1

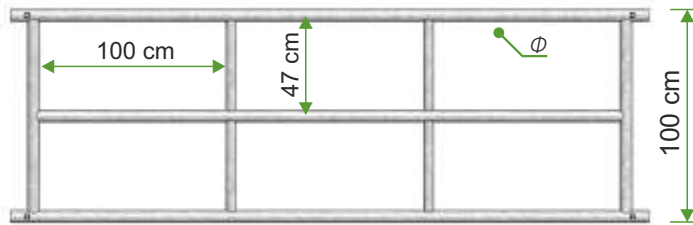

- 3 **W10-05-00-15** Divider PST-2 HDG (Φ 60,3 mm) pcs
- 4 **W10-05-00-17** Divider PST-2-1 HDG (Φ 48,3 mm) pcs

DIVIDER PST - 3 , PST - 3-1

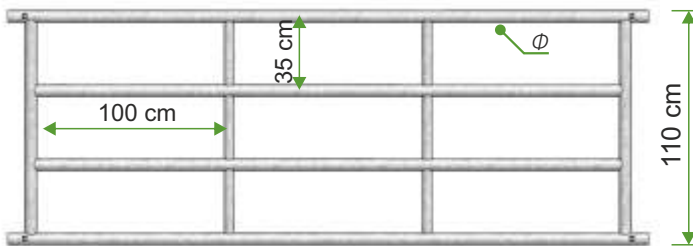

- 5 **W10-05-00-19** Divider PST-3 HDG (Φ 60,3 mm) pcs
- 6 **W10-05-00-21** Divider PST-3-1 HDG (Φ 48,3 mm) pcs

ADJUSTABLE GATES

GATE FP 1 , FP 1-1



- 1 **W10-05-03** Gate FP-1 HDG (Φ 60,3 mm) pcs
- 2 **W10-05-04** Gate FP-1-1 HDG (Φ 48,3 mm) pcs

GATE FP 2 , FP 2-1

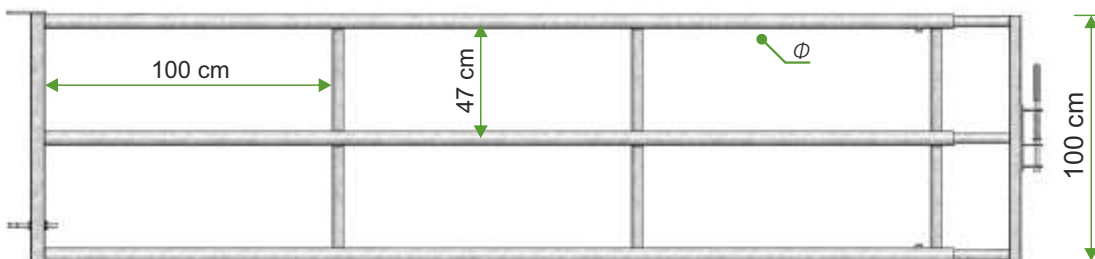

- 3 **W10-05-07** Gate FP-2 HDG (Φ 60,3 mm) pcs
- 4 **W10-05-08** Gate FP-2-1 HDG (Φ 48,3 mm) pcs

HDG - anti-corrosion protection - hot-dip galvanized.



CALF BOXES

① KC-1B



② KC-2B



- length (outer/inner size): 158,5/147,5 cm ; width (outer/inner size): 103/94 cm ; height (outer/inner size): 132,5/110 cm ;
- height-adjustable feets, - floor made from pine wood, - openable front wall with additional drinker holder;
- dimensions : length - 60 cm ; width - 38 cm ; height- 40 cm.

1	W10-13-14	Calf boxes KC-1 B HDG	set
2	W10-13-09	Calf boxes KC-2 B HDG	set
3	W10-08-71	Calf box feeder HDG	pcs

HDG - anti-corrosion protection - hot-dip galvanized.