

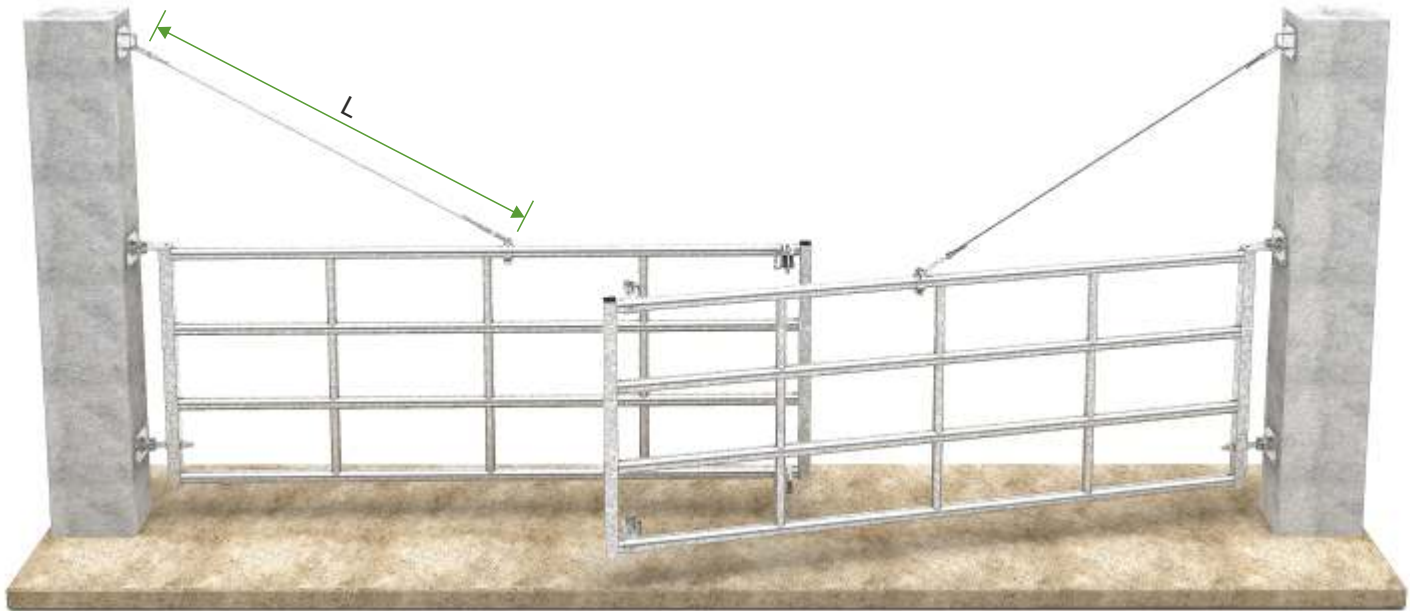



GATES ELEMENTS



L - length adjusted to the gate

USAGE EXAMPLES

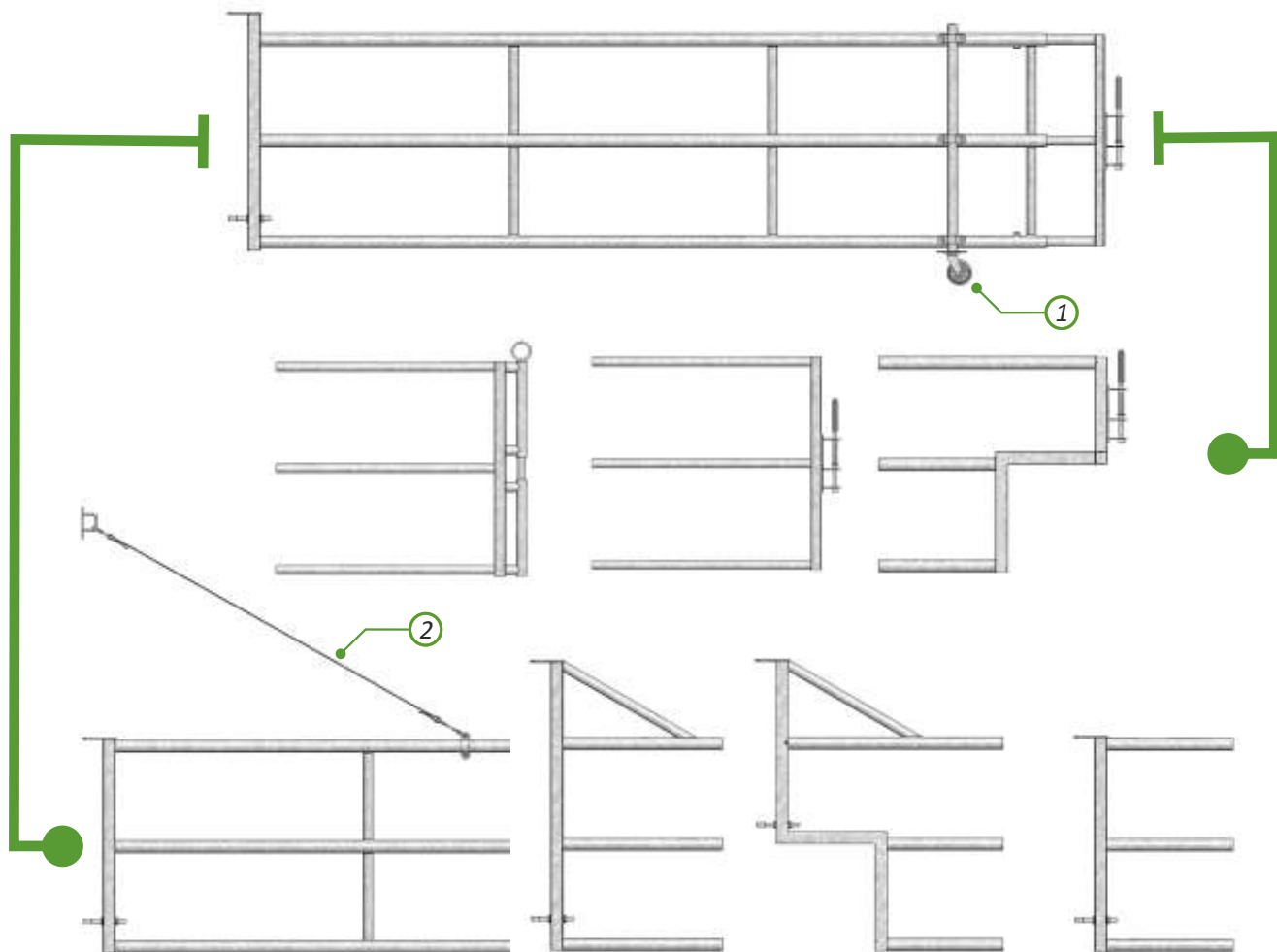

- 1 **W10-05-00-03** Gate support wheel HDG set
- 2 **W10-05-00-01** Gate bracing HDG set

HDG - anti-corrosion protection - hot-dip galvanized.





FILLED GATE

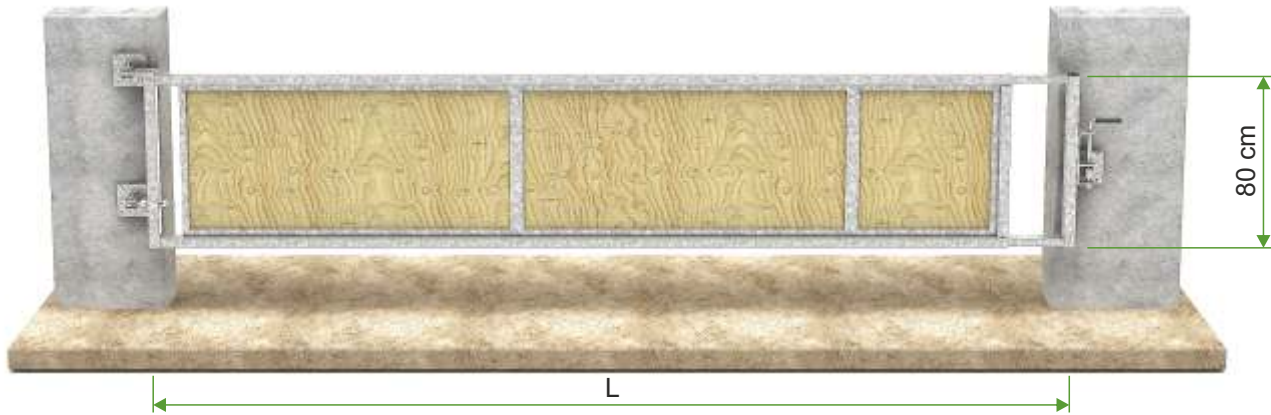

Gate made of RHS 50x3 mm, filled with 12 mm waterproof plywood, span L - 1,2-5 m.

1 **W10-05-57** Filled gate FPE HDG pcs

SLIDING GATE

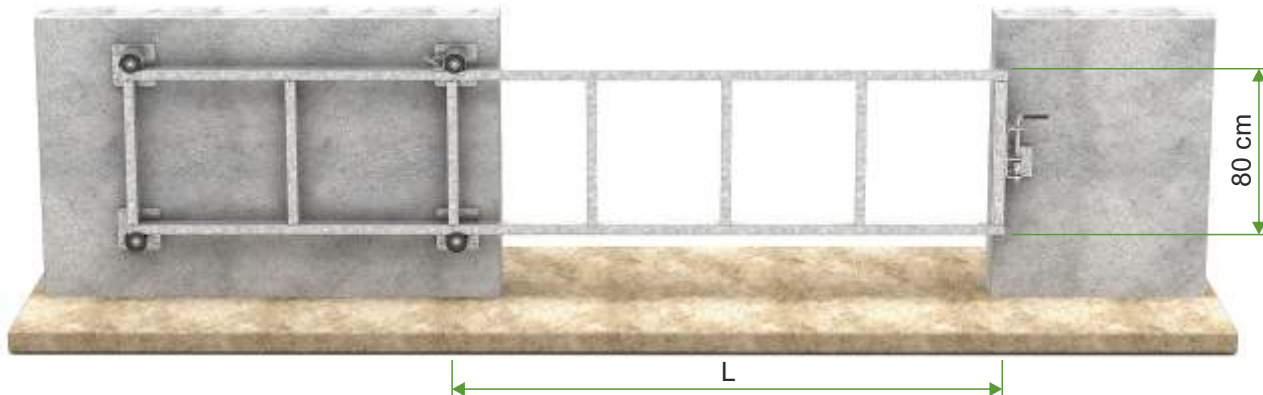

Gate made of RHS 50x3 mm profile, span L - 1,2-5 m.
(Possibility to fill with waterproof plywood 12 mm)

1 **W10-05-45** Sliding gate FPP - 2 HDG pcs

LIFTABLE GATE

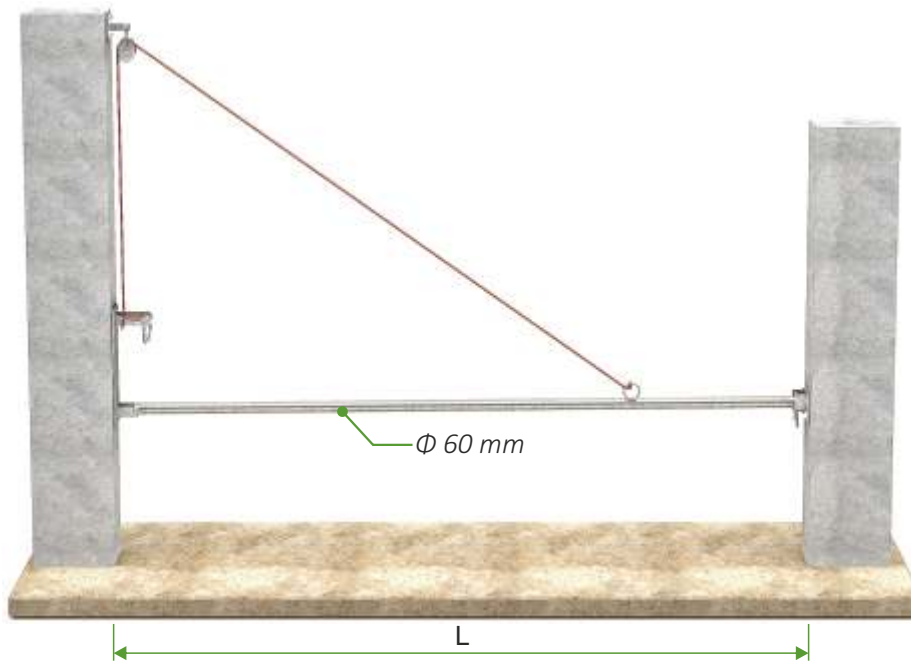

Gate span 2 - 3 m , polypropylene rope 10 mm.

1 **W10-05-38** Liftable gate FPG - 1 HDG pcs

HDG - anti-corrosion protection - hot-dip galvanized.





DIVIDERS

DIVIDER PST - 1 , PST - 1-1



- 1 **W10-05-00-11** Divider PST-1 HDG (Φ 60,3 mm) pcs
- 2 **W10-05-00-13** Divider PST-1-1 HDG (Φ 48,3 mm) pcs

DIVIDER PST - 2 , PST - 2-1

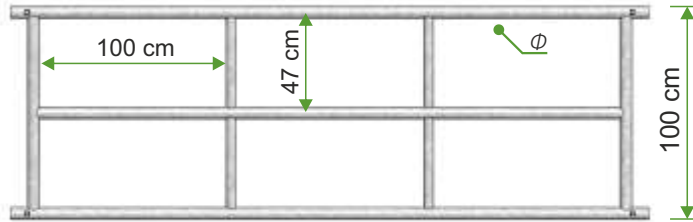

- 3 **W10-05-00-15** Divider PST-2 HDG (Φ 60,3 mm) pcs
- 4 **W10-05-00-17** Divider PST-2-1 HDG (Φ 48,3 mm) pcs

DIVIDER PST - 3 , PST - 3-1

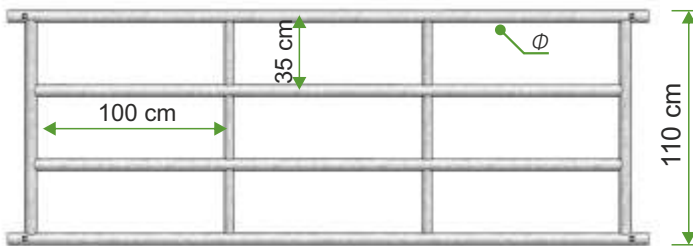

- 5 **W10-05-00-19** Divider PST-3 HDG (Φ 60,3 mm) pcs
- 6 **W10-05-00-21** Divider PST-3-1 HDG (Φ 48,3 mm) pcs

ADJUSTABLE GATES

GATE FP 1 , FP 1-1

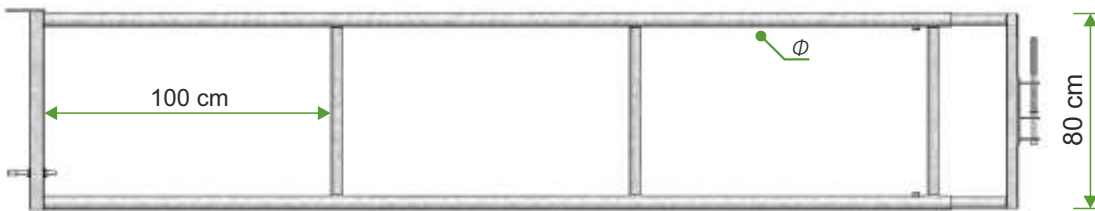

- 1 **W10-05-03** Gate FP-1 HDG (Φ 60,3 mm) pcs
- 2 **W10-05-04** Gate FP-1-1 HDG (Φ 48,3 mm) pcs

GATE FP 2 , FP 2-1

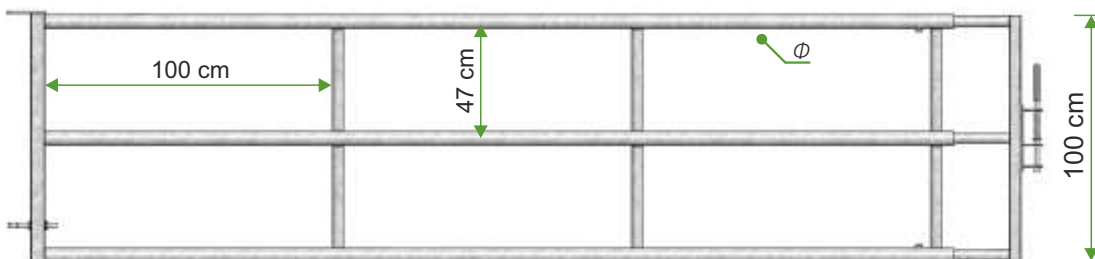

- 3 **W10-05-07** Gate FP-2 HDG (Φ 60,3 mm) pcs
- 4 **W10-05-08** Gate FP-2-1 HDG (Φ 48,3 mm) pcs

HDG - anti-corrosion protection - hot-dip galvanized.





GATE FP - 3, FP - 3-1

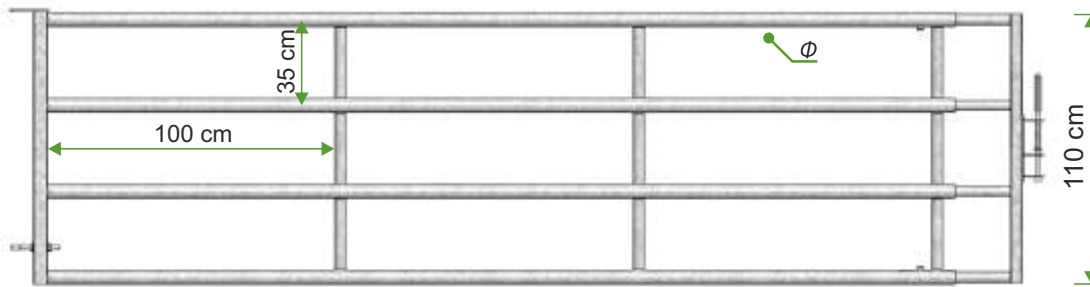

- 11 **W10-05-12** Gate FP-3 HDG (Φ 60,3 mm) pcs
- 12 **W10-05-13** Gate FP-3-1 HDG (Φ 48,3 mm) pcs

GATE FP - 4

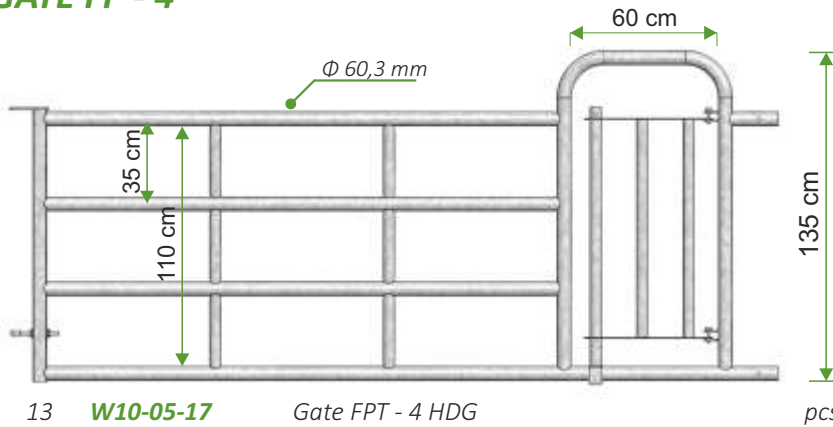

- 13 **W10-05-17** Gate FPT - 4 HDG pcs

BEEF CATTLE GATE FBO - 1

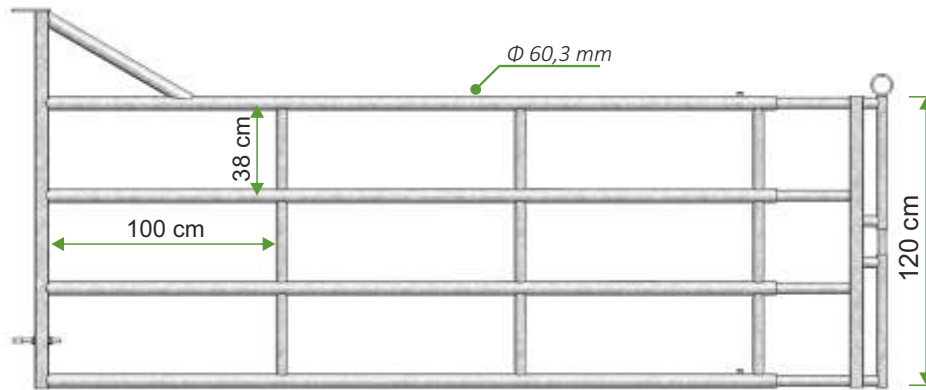

- 14 **W10-05-32** Beef cattle gate FBO - 1 HDG pcs

BEEF CATTLE GATE FBO - 2

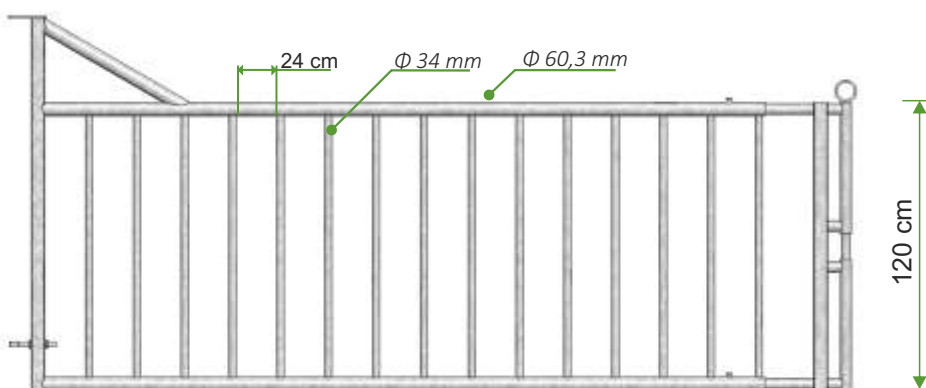

- 15 **W10-05-35** Beef cattle gate FBO - 2 HDG pcs
- HDG - anti-corrosion protection - hot-dip galvanized.



POSTS

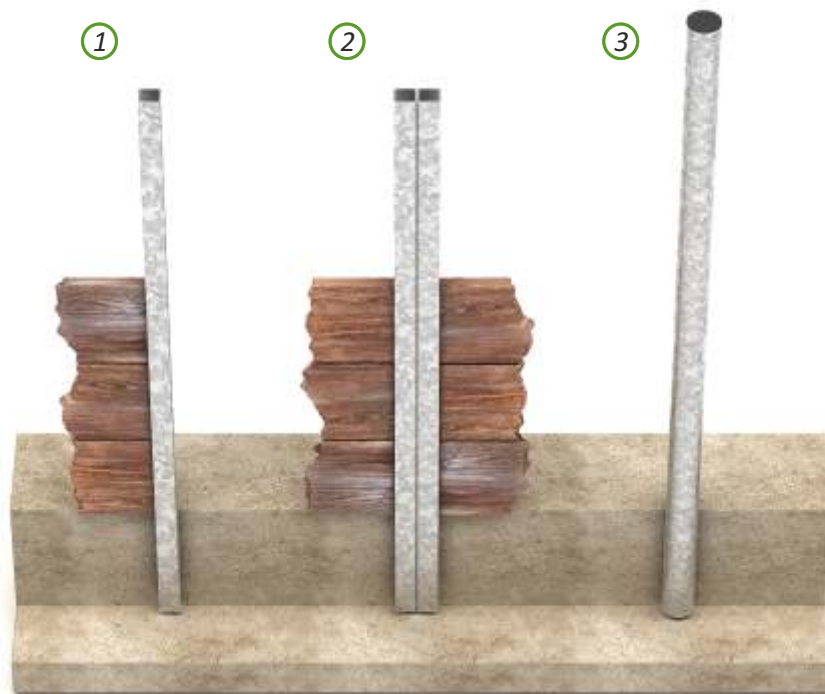

- | | | | |
|---|------------------|-------------------------------------|-----|
| 1 | W10-10-31 | Post CB L-1,5 m HDG | psc |
| 2 | W10-10-33 | Post HB L-1,5 m HDG | pcs |
| 3 | W10-10-06 | Post B L-1,4 m HDG (pvp cap incl.) | set |
| 3 | W10-10-16 | Post B L-1,7 m HDG (pvp cap incl.) | set |

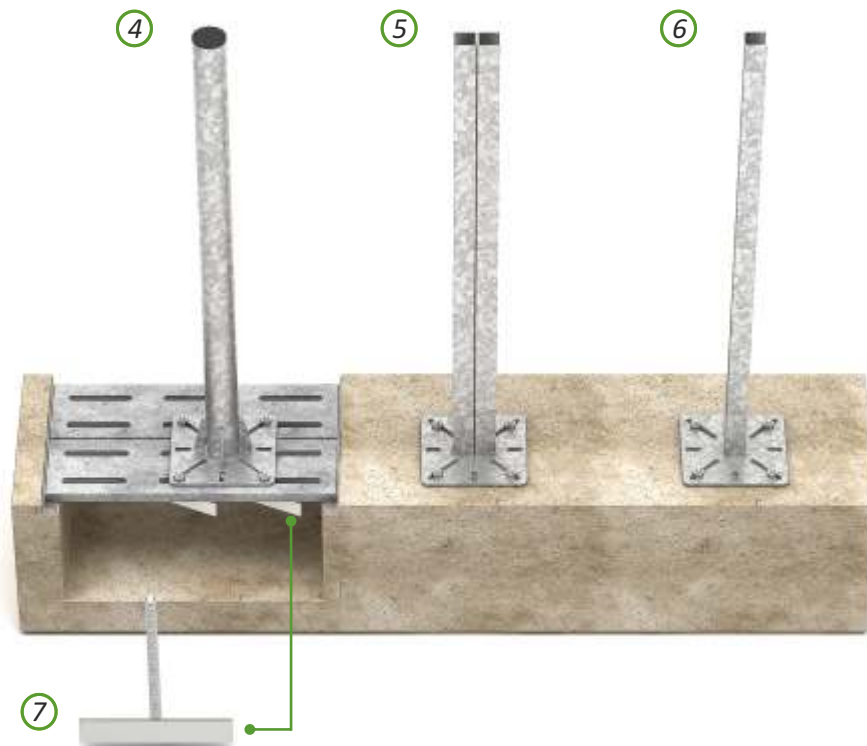

- | | | | |
|---|------------------|-------------------------------------|------|
| 4 | W10-10-02 | Post P L-1,2 m HDG (pvp cap incl.) | kpl. |
| 4 | W10-10-11 | Post P L-1,4 m HDG (pvp cap incl.) | kpl. |
| 5 | W10-10-37 | Post HP L-1,2 m HDG | szt. |
| 6 | W10-10-35 | Post CP L-1,2 m HDG | pcs |
| 7 | W10-92-70 | Kotwa do ruszt INOX | pcs |

HDG - anti-corrosion protection - hot-dip galvanized.



LOCKS AND HINGES

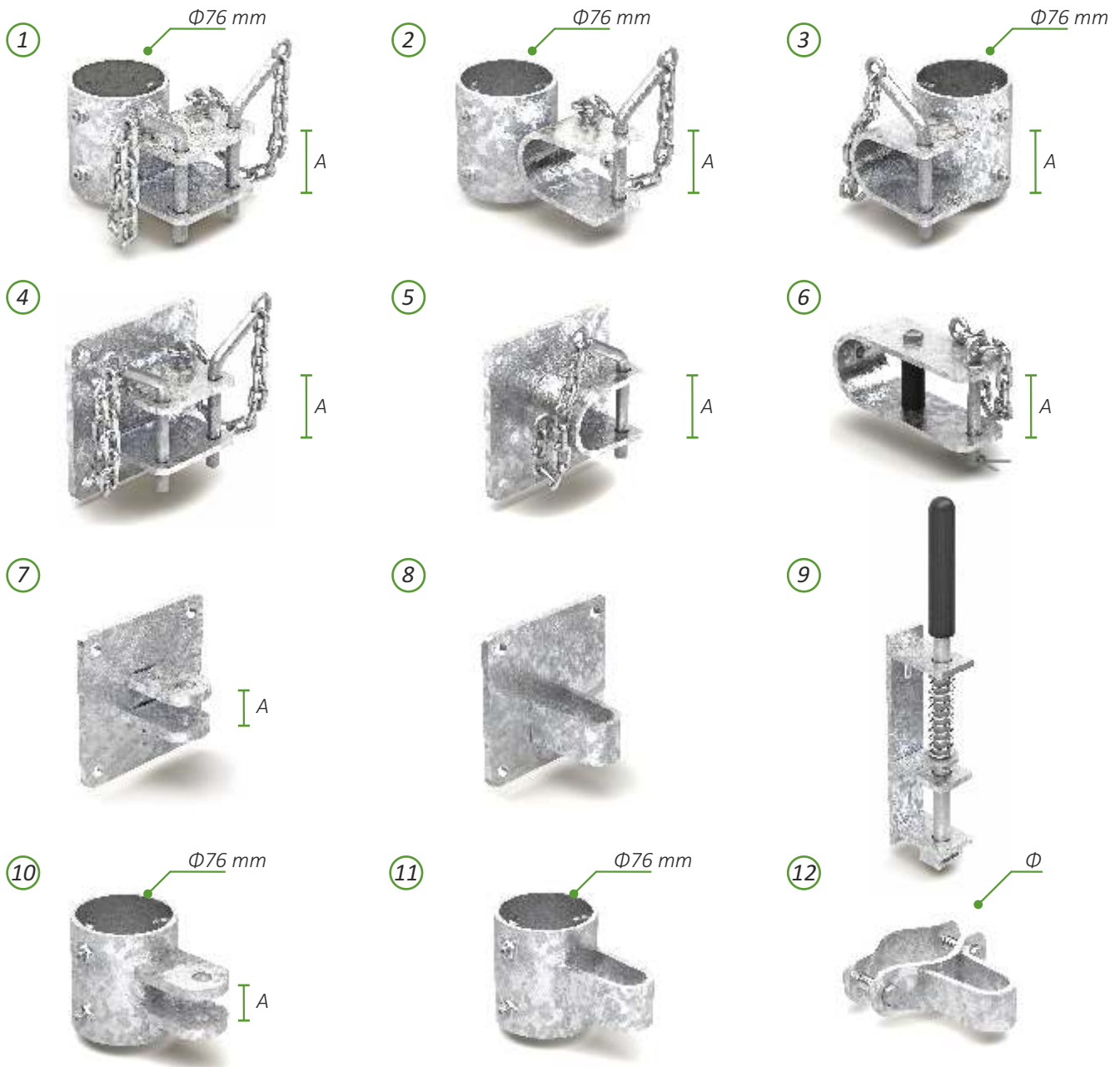

			DIAMETER Φ mm	DIMENSION A mm	
1	P10-04-28-03	Pipe lock ZMR76-P1-1-I HDG	76	50	set
1.1	P10-04-28-04	Pipe lock ZMR76-P2-1-I HDG	76	62	set
2	P10-04-28-05	Pipe lock ZMR76-U3-1-I HDG	76	50	set
2.1	P10-04-28-06	Pipe lock ZMR76-U4-1-I HDG	76	62	set
3	P10-04-28-07	Pipe lock ZMR76-U1-1-I HDG	76	50	set
3.1	P10-04-28-08	Pipe lock ZMR76-U2-1-I HDG	76	62	set
4	P10-04-28-11	Wall lock ZMS-P1-1-I HDG		50	set
4.1	P10-04-28-12	Wall lock ZMS-P2-1-I HDG		62	set
5	P10-04-28-13	Wall lock ZMS-U1-1-I HDG		50	set
5.1	P10-04-28-14	Wall lock ZMS-U2-1-I HDG		62	set
6	P10-04-28-15	Wall lock ZMC 1 HDG		62	set
7	P10-04-28-16	Lock ZMS-Z1-1-I HDG		25	pcs
8	P10-04-28-17	Wall lock ZMS-S1-1-I HDG			pcs
9	P10-04-28-02	Spring lock ZFSP HDG			pcs
10	P10-04-28-09	Pipe lock ZMR76-Z1-1-I HDG	76		pcs
11	P10-04-28-10	Pipe lock ZMR76-S1-1-I HDG	76		pcs
12	P10-04-28-18	Pipe lock ZMR60-S1-1-I HDG	60 - 76		pcs

HDG - anti-corrosion protection - hot-dip galvanized.



CONNECTORS

1



Usage:
- for fixing free-stall dividers neck rails.

- | | | | |
|-----|-------------------|---------------------------|--|
| 1 | W10-90-06 | Cross clamp HDG | |
| 2 | T10-90-340 | Angle cross clamp 33 INOX | |
| 2.1 | T10-90-370 | Angle cross clamp 48 INOX | |
| 2.2 | T10-90-390 | Angle cross clamp 60 INOX | |

2



Usage:
- for fixing free-stall dividers neck rails.

- | | | | |
|-----|--|--|--|
| set | | | |
| pcs | | | |
| pcs | | | |
| pcs | | | |

3



Usage:
- for fixing feeding fences;
- for fixing free-stall dividers main pipes.

- | | | | |
|-----|------------------|------------------------------------|-----|
| 3 | W10-90-46 | Mounting clamp HDG | pcs |
| 3.1 | W10-90-51 | Small mounting clamp HDG | pcs |
| 4 | W10-91-35 | Cross conector 1 1/2" - 2" HDG | pcs |
| 4.1 | W10-91-39 | Cross conector 1 1/2" - 1 1/2" HDG | pcs |
| 4.2 | W10-91-41 | Cross conector 2" - 2" HDG | pcs |
| 4.3 | W10-91-43 | Cross conector 2,5" - 2" HDG | pcs |

4

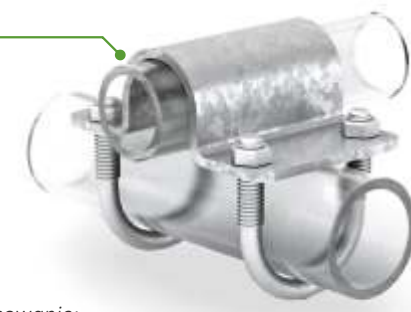

Zastosowanie:
- for fixing free-stall dividers neck rails;
- for fixing horizontal pipes 1 1/2", 2", 2 1/2".

5



Usage:
- for fixing Kombibox divider with Kombibox arch;
- for fixing feeding fences made from pipe 1 1/2" and 2";
- for fixing pipe 1 1/2" and 2";
- for fixing dividers type VII and X main pipes.

- | | | | |
|-----|-------------------|---------------------------|-----|
| 5 | T10-90-140 | U-shaped clamp C 42 INOX | pcs |
| 5.1 | T10-90-150 | U-shaped clamp C 48 INOX | pcs |
| 5.2 | T10-90-160 | U-shaped clamp C 60 INOX | pcs |
| 5.3 | T10-90-180 | U-shaped clamp C 76 INOX | pcs |
| 5.4 | T10-90-190 | U-shaped clamp C 90 INOX | pcs |
| 5.5 | T10-90-270 | U-shaped clamp C 133 INOX | pcs |
| 5.6 | T10-90-290 | U-shaped clamp C 159 INOX | pcs |
| 5.7 | T10-90-320 | U-shaped clamp C 250 INOX | pcs |
| 5.8 | T10-90-330 | U-shaped clamp C 300 INOX | pcs |
| 6 | W10-92-14 | Wall mount 48 HDG | pcs |
| 6.1 | W10-92-17 | Wall mount 60 HDG | pcs |

HDG - anti-corrosion protection - hot-dip galvanized.

6



Usage:
- for fixing feeding fences made from pipe 1 1/2" and 2" to wall;
- for fixing neck rails dividers type VII, III, IX, X to wall.



7



Usage:

- for fixing free-stall type VII and free-stall type X with main pipe.

- 7 **T10-91-68** T-shaped clamp 2" x 2" HDG set
- 7.1 **T10-91-720** T-shaped clamp 2 1/2 x 1 1/2" HDG set
- 7 **T10-91-725** T-shaped clamp 2 1/2 x 2 HDG set
- 8.1 **W10-91-83** Double T-clamp 2" / 2" HDG set

8



Usage:

- for head fixing free-stall type VII and for fixing free-stall type X with main pipe in double rows boxes.

9



Usage:

- for fixing free-stall types III, VII, IX, X dividers neck rails;
- for fixing free-stall types III, VII, IX, X dividers main pipes;
- for fixing neck rails insted of using feeding fences.

- 9 **W10-92-26** 1,5" Pipe HDG conector pcs
- 9.1 **W10-92-27** 2" Pipe HDG conector pcs
- 10 **W10-91-12** Straigh pipe conector 1 1/2" pipe HDG set
- 10.1 **W10-91-14** Straigh pipe conector 2" pipe HDG set

10



Usage:

- for fixing free-stall types III, VII, IX, X dividers neck rails;
- for fixing free-stall types III, VII, IX, X dividers main pipes;
- for fixing neck rails insted of using feeding fences.

11



- made of low-density polyethylene;
- usage as tube or post cup.

- 11 **T32-31-050** PVC cup 1" pcs
- 11.1 **T32-31-060** PVC cup 1 1/4" pcs
- 11.2 **T32-31-070** PVC cup 1 1/2" pcs
- 11.3 **T32-31-080** PVC cup 2" pcs
- 11.4 **T32-31-100** PVC cup 2 1/2" pcs
- 12 **W10-04-99** Holder for feeding fences HDG pcs

HDG - anti-corrosion protection - hot-dip galvanized.

12



Usage:

- for fixing 2" horizotnal pipes;;
- for fixing feeding fences in bend over position.