

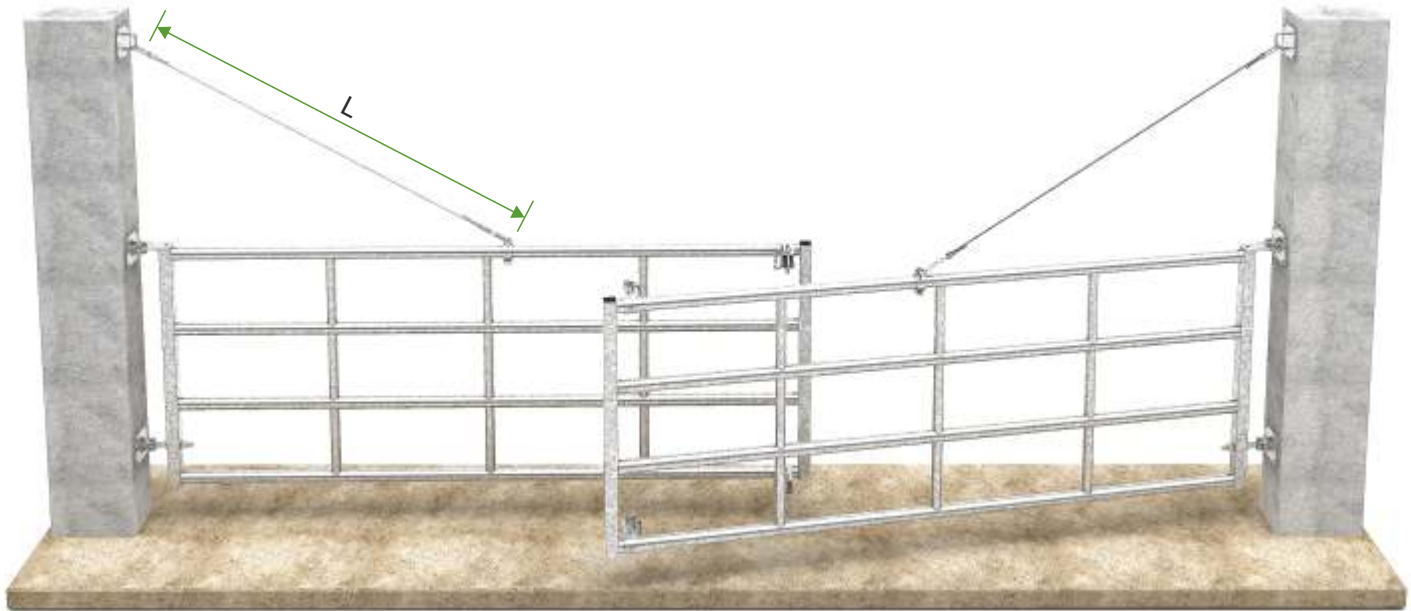



GATES ELEMENTS



L - length adjusted to the gate

USAGE EXAMPLES

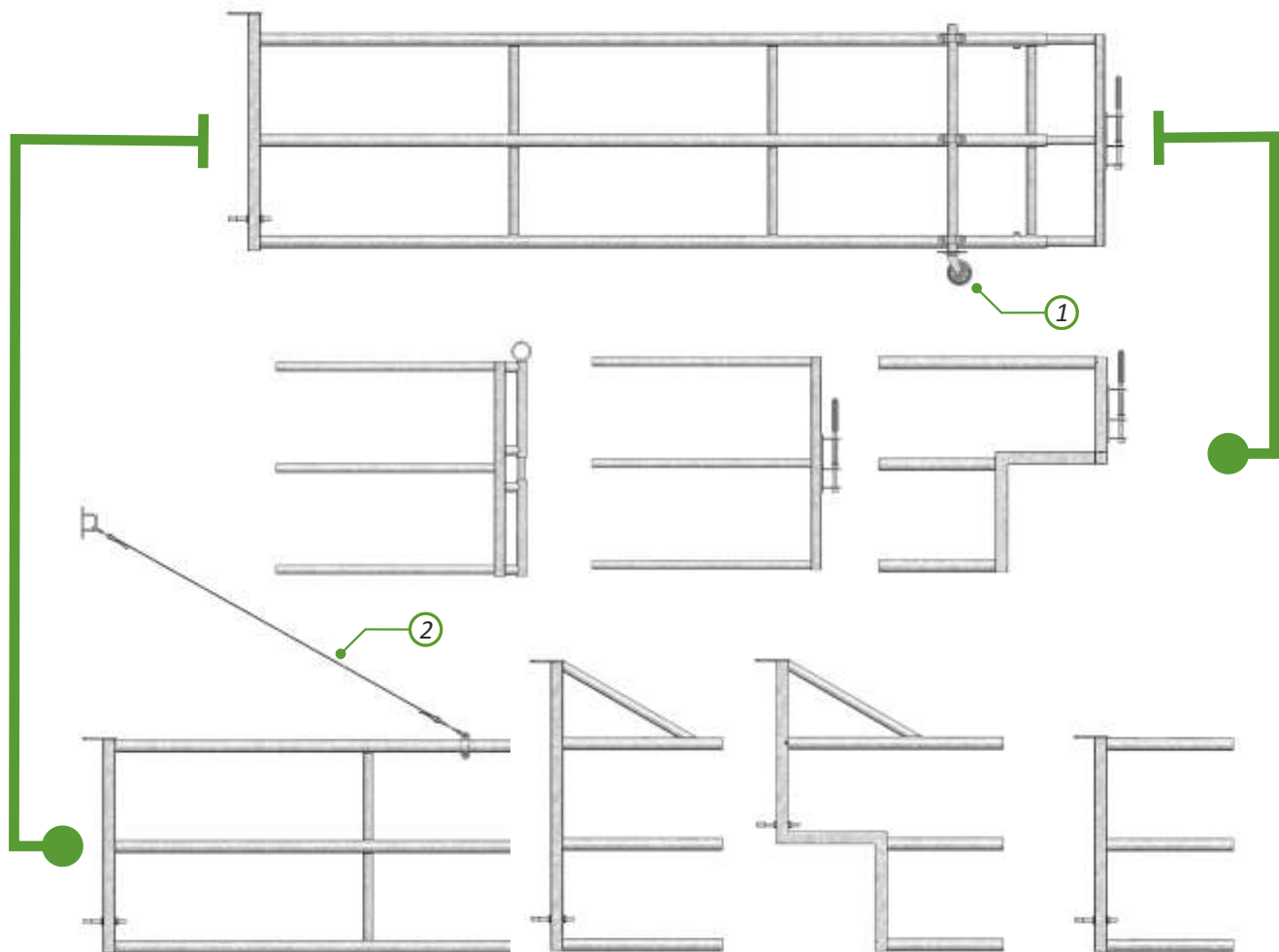

- 1 **W10-05-00-03** Gate support wheel HDG set
- 2 **W10-05-00-01** Gate bracing HDG set

HDG - anti-corrosion protection - hot-dip galvanized.





FILLED GATE

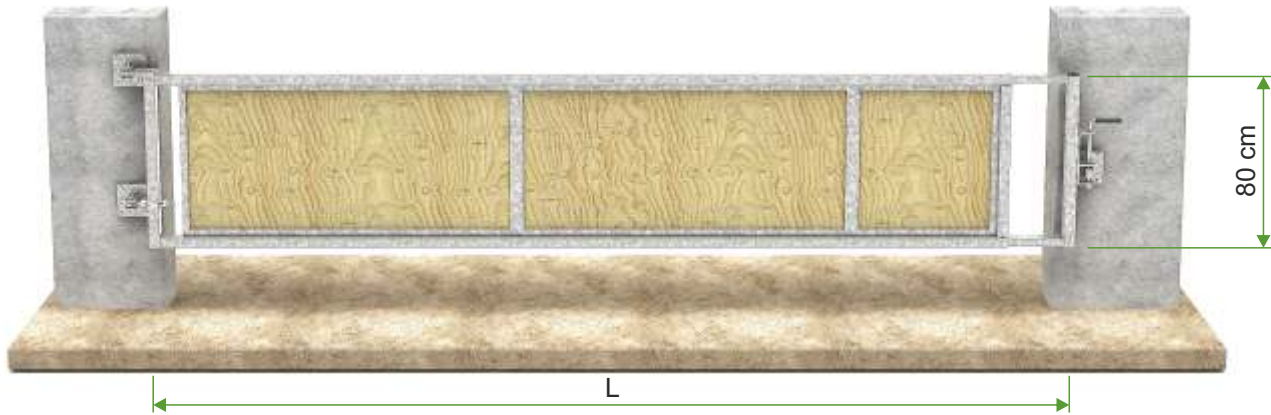

Gate made of RHS 50x3 mm, filled with 12 mm waterproof plywood, span L - 1,2-5 m.

1 **W10-05-57** Filled gate FPE HDG pcs

SLIDING GATE

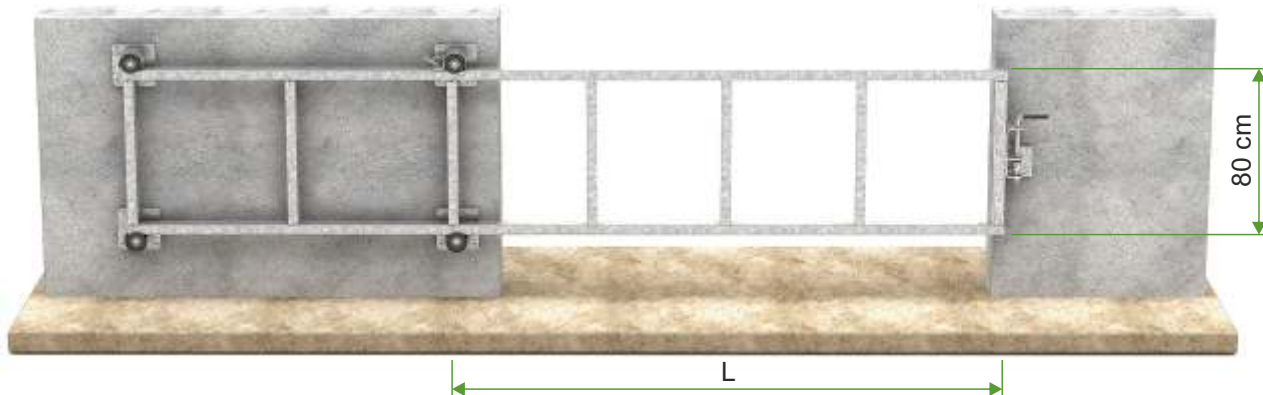

Gate made of RHS 50x3 mm profile, span L - 1,2-5 m.
(Possibility to fill with waterproof plywood 12 mm)

1 **W10-05-45** Sliding gate FPP - 2 HDG pcs

LIFTABLE GATE

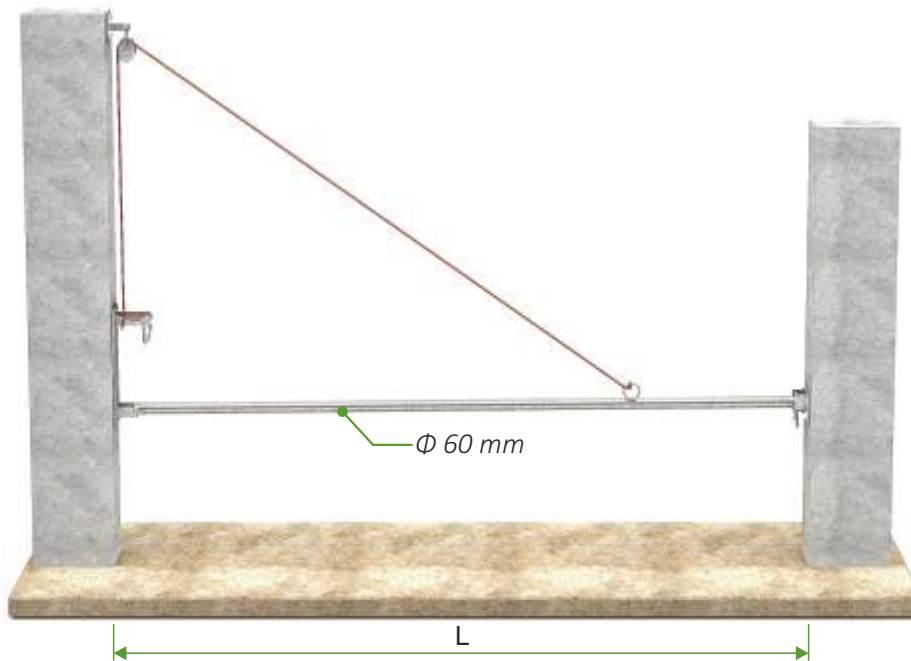

Gate span 2 - 3 m , polypropylene rope 10 mm.

1 **W10-05-38** Liftable gate FPG - 1 HDG pcs

HDG - anti-corrosion protection - hot-dip galvanized.





DIVIDERS

DIVIDER PST - 1 , PST - 1-1



- 1 **W10-05-00-11** Divider PST-1 HDG (Φ 60,3 mm) pcs
- 2 **W10-05-00-13** Divider PST-1-1 HDG (Φ 48,3 mm) pcs

DIVIDER PST - 2 , PST - 2-1

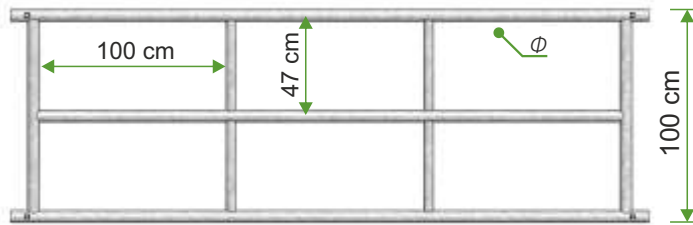

- 3 **W10-05-00-15** Divider PST-2 HDG (Φ 60,3 mm) pcs
- 4 **W10-05-00-17** Divider PST-2-1 HDG (Φ 48,3 mm) pcs

DIVIDER PST - 3 , PST - 3-1

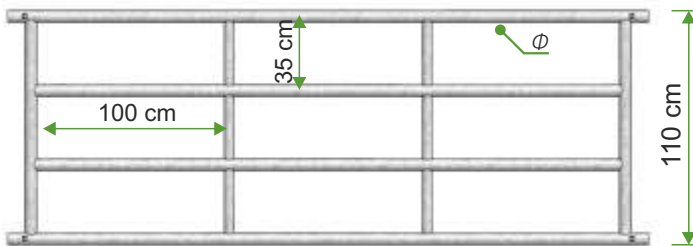

- 5 **W10-05-00-19** Divider PST-3 HDG (Φ 60,3 mm) pcs
- 6 **W10-05-00-21** Divider PST-3-1 HDG (Φ 48,3 mm) pcs

ADJUSTABLE GATES

GATE FP 1 , FP 1-1

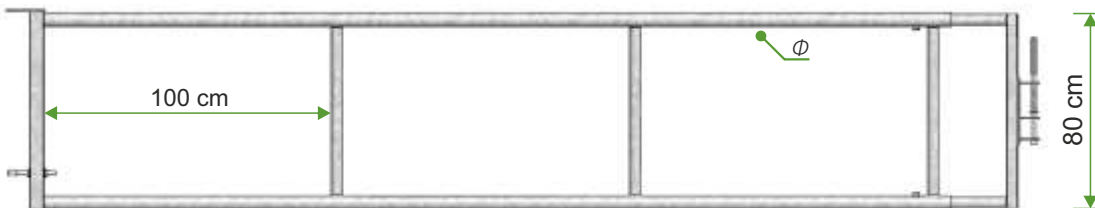

- 1 **W10-05-03** Gate FP-1 HDG (Φ 60,3 mm) pcs
- 2 **W10-05-04** Gate FP-1-1 HDG (Φ 48,3 mm) pcs

GATE FP 2 , FP 2-1

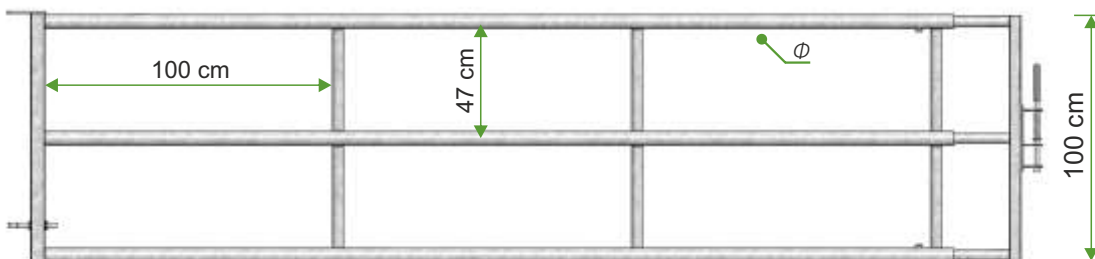

- 3 **W10-05-07** Gate FP-2 HDG (Φ 60,3 mm) pcs
- 4 **W10-05-08** Gate FP-2-1 HDG (Φ 48,3 mm) pcs

HDG - anti-corrosion protection - hot-dip galvanized.





GATE FP - 3, FP - 3-1

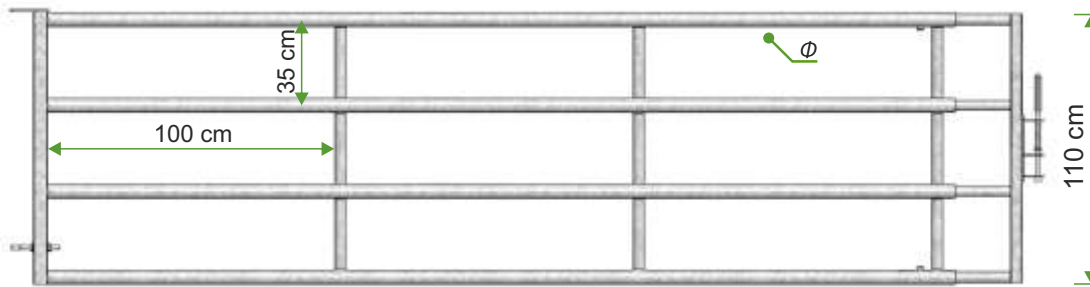

- 11 **W10-05-12** Gate FP-3 HDG (Φ 60,3 mm) pcs
- 12 **W10-05-13** Gate FP-3-1 HDG (Φ 48,3 mm) pcs

GATE FP - 4

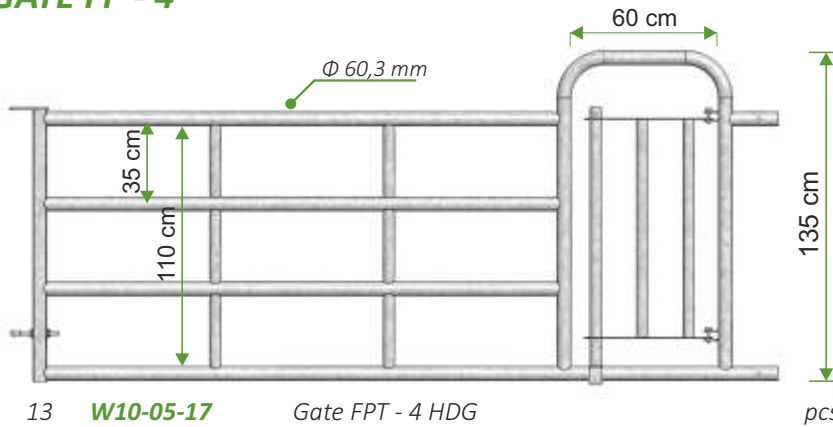

- 13 **W10-05-17** Gate FPT - 4 HDG pcs

BEEF CATTLE GATE FBO - 1

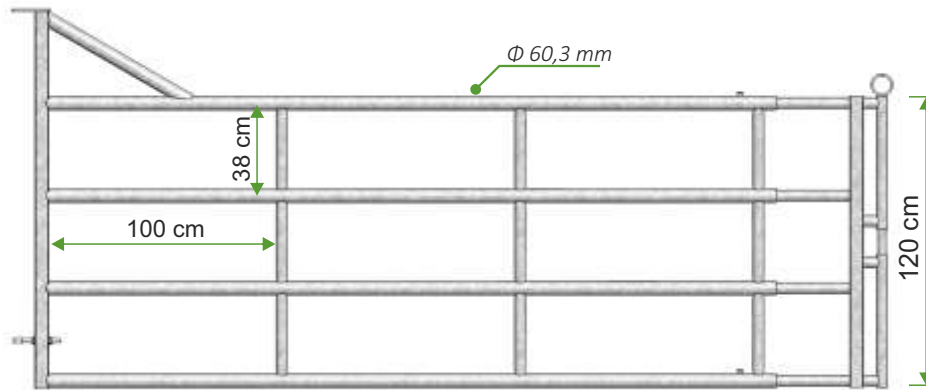

- 14 **W10-05-32** Beef cattle gate FBO - 1 HDG pcs

BEEF CATTLE GATE FBO - 2

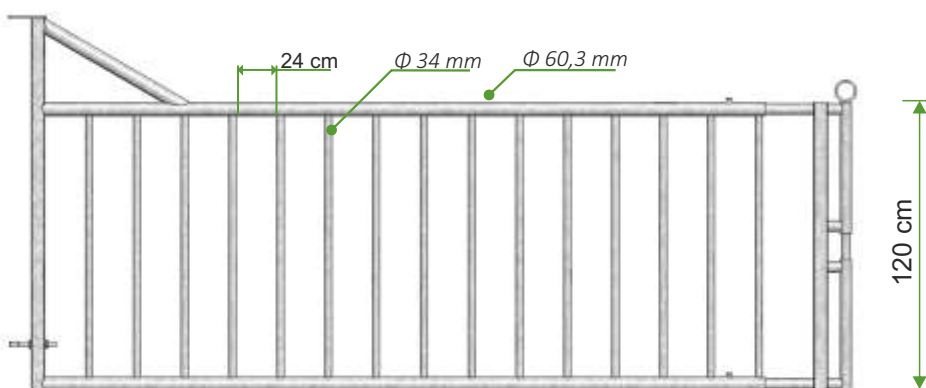

- 15 **W10-05-35** Beef cattle gate FBO - 2 HDG pcs
- HDG - anti-corrosion protection - hot-dip galvanized.



POSTS

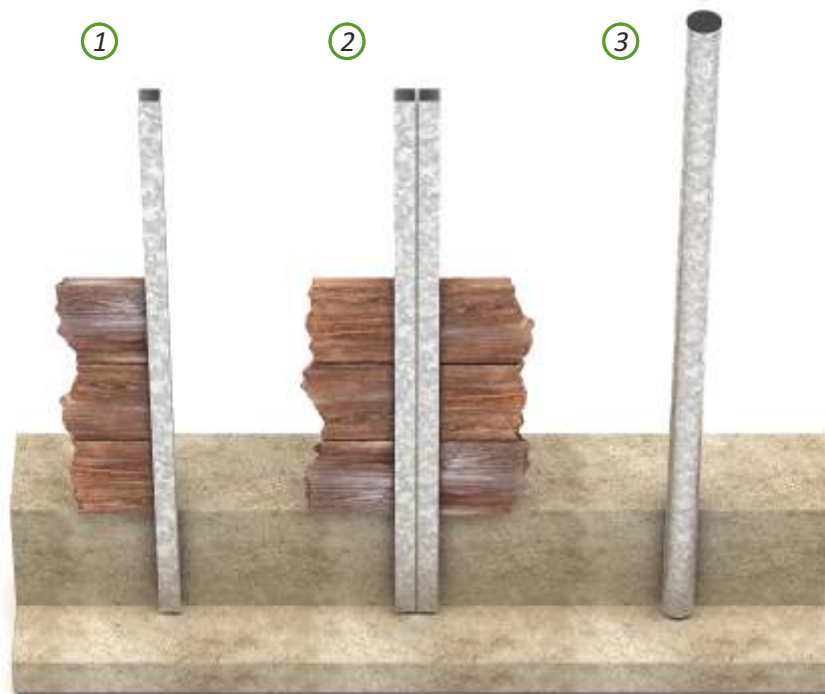

- | | | | |
|---|------------------|-------------------------------------|-----|
| 1 | W10-10-31 | Post CB L-1,5 m HDG | psc |
| 2 | W10-10-33 | Post HB L-1,5 m HDG | pcs |
| 3 | W10-10-06 | Post B L-1,4 m HDG (pvp cap incl.) | set |
| 3 | W10-10-16 | Post B L-1,7 m HDG (pvp cap incl.) | set |

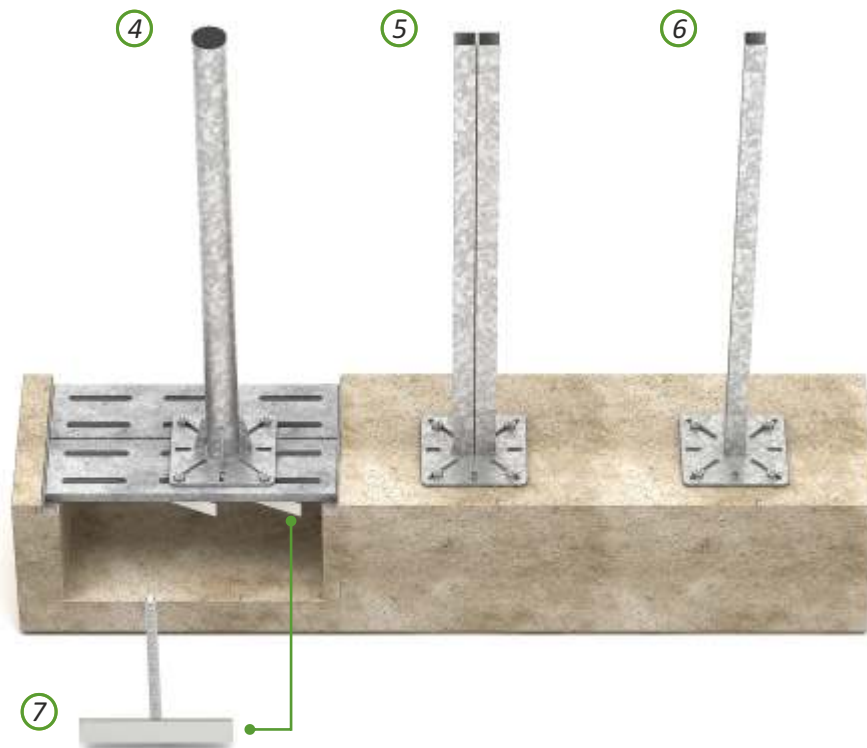

- | | | | |
|---|------------------|-------------------------------------|------|
| 4 | W10-10-02 | Post P L-1,2 m HDG (pvp cap incl.) | kpl. |
| 4 | W10-10-11 | Post P L-1,4 m HDG (pvp cap incl.) | kpl. |
| 5 | W10-10-37 | Post HP L-1,2 m HDG | szt. |
| 6 | W10-10-35 | Post CP L-1,2 m HDG | pcs |
| 7 | W10-92-70 | Kotwa do ruszt INOX | pcs |

HDG - anti-corrosion protection - hot-dip galvanized.