

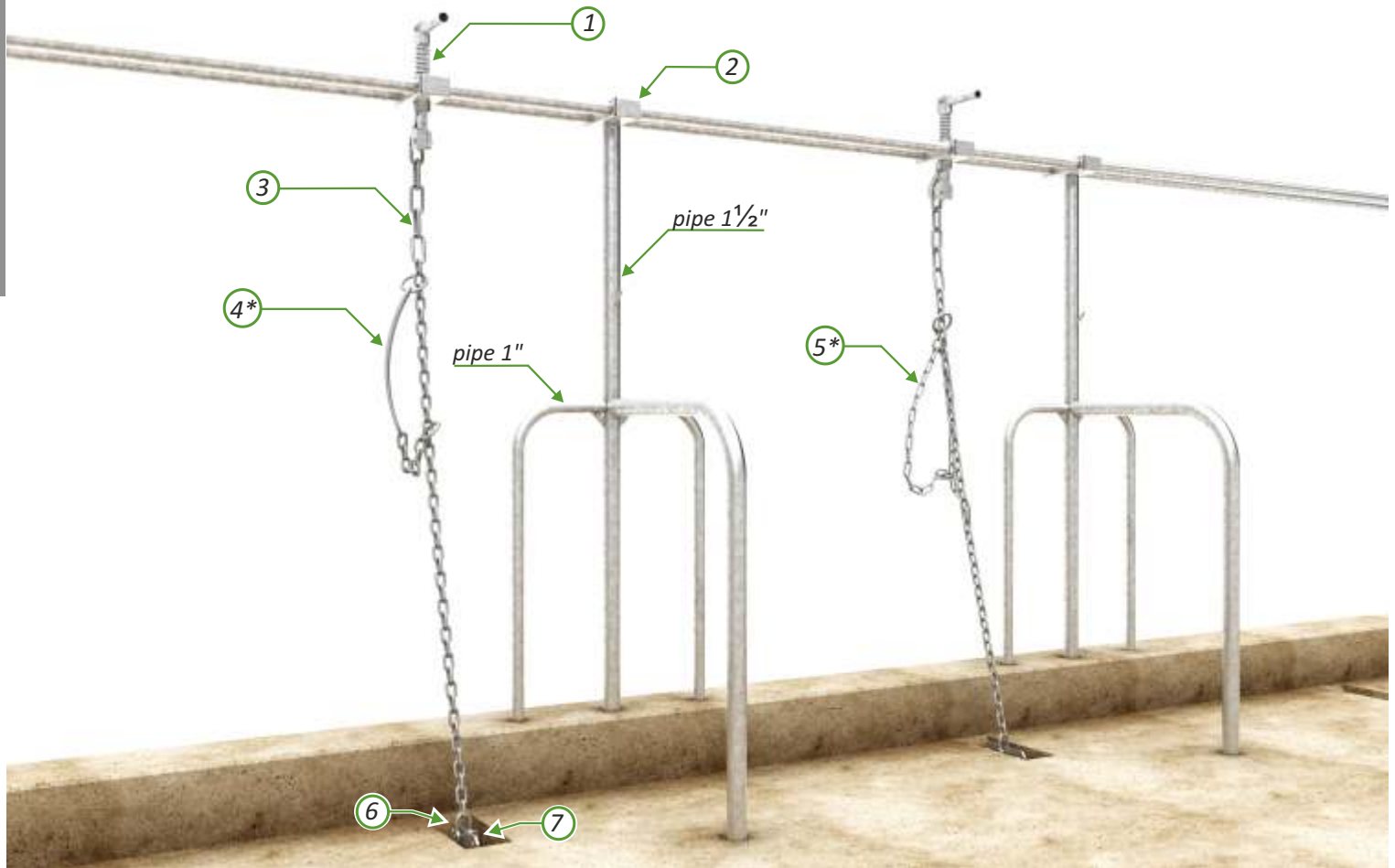

TIE-STALL TYPE A

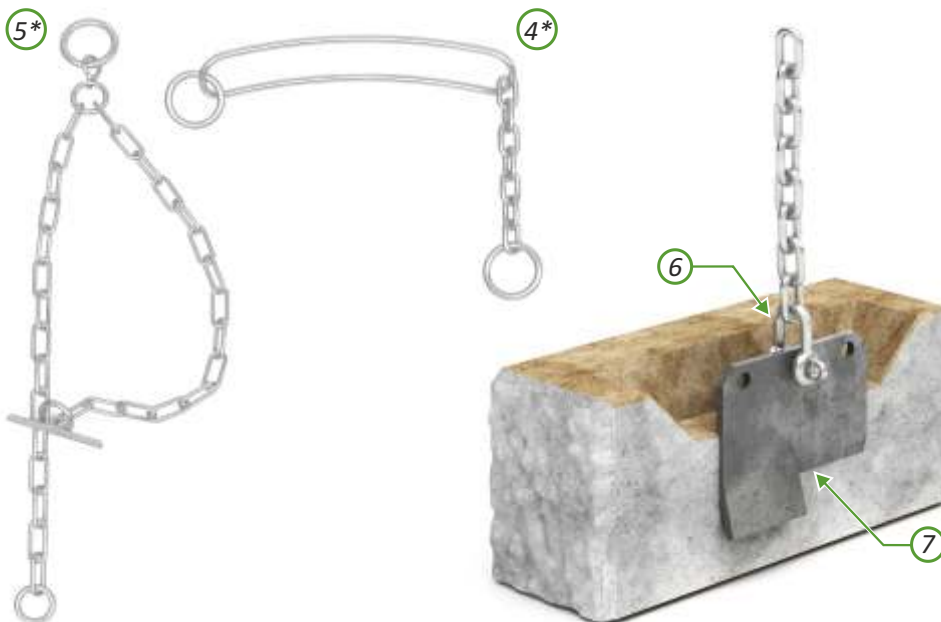

* to choose joker (4*) or chain braket (5*)



Latch tie HDG



Tie-stall clamp

1	W10-03-19	Latch tie HDG	pcs
2	W10-02-17	Tie-stall clamp type A HDG	set
3	W10-03-28	Vertical chain type A HDG	pcs
4	W10-03-16	Joke HDG	pcs
5	W10-03-06	Chain braket HDG	pcs
6	T33-05-01	Schackle M 10	pcs
7	W10-03-10	Anchor HDG	pcs

HDG - anti-corrosion protection - hot-dip galvanized.



SYSTEM ELEMENTS

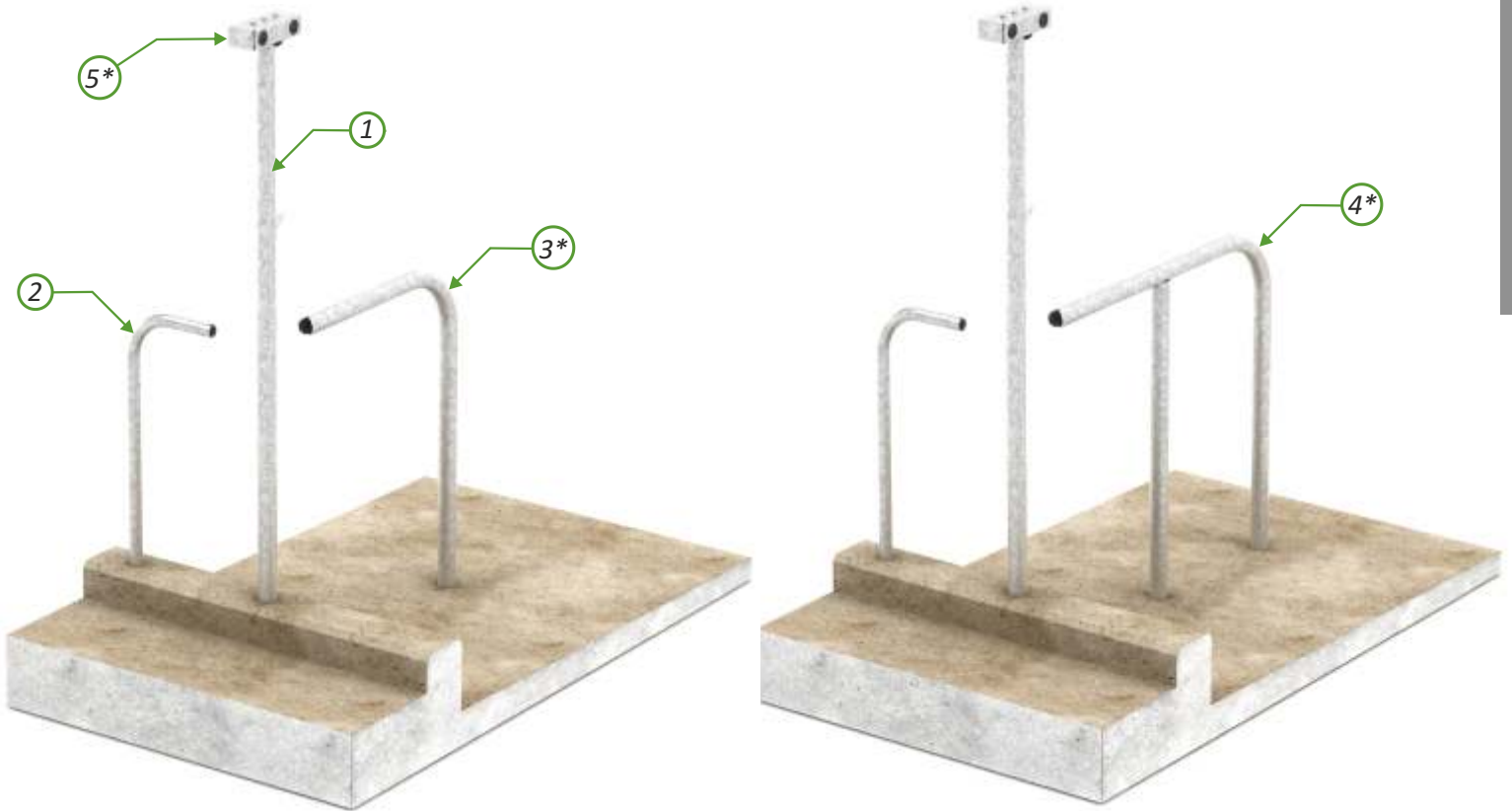

3*, 4* - two types of tie-stall rear arches curves to choose

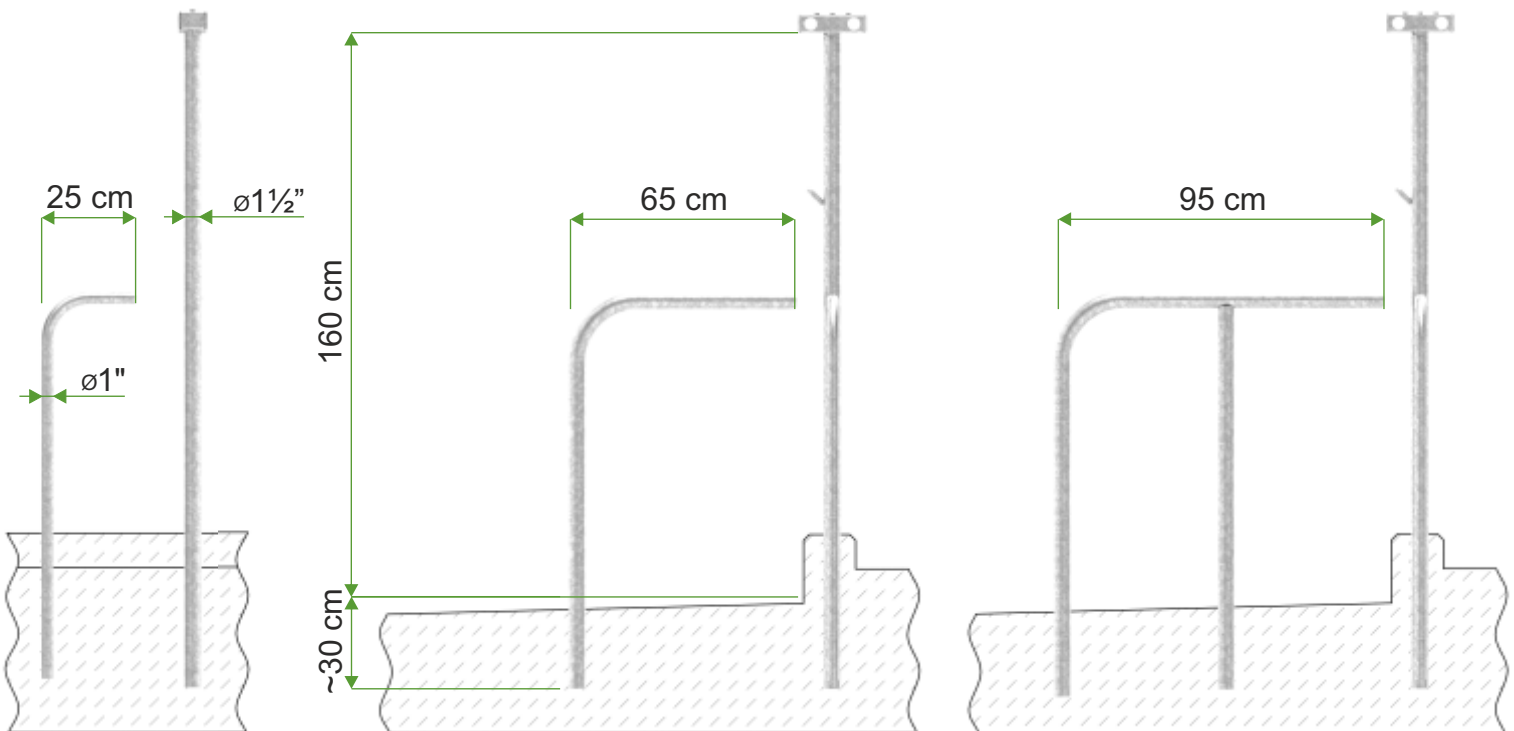

- | | | | |
|---|------------------|---|-----|
| 1 | W10-02-22 | Steel post to Tie-Stall type A HGD | pcs |
| 2 | W10-02-32 | Tie-stall side steel arch HDG | pcs |
| 3 | W10-02-37 | Tie-stall rear steel arch HDG | pcs |
| 4 | W10-02-43 | Tie-stall rear steel arch VI HDG | pcs |
| 5 | W10-02-17 | Tie-stall clamp type A (without screws M10x80) | set |

HDG - anti-corrosion protection - hot-dip galvanized

*5 - Screws M10x80 (2 pcs) - not included in set.



TIE-STALL IA

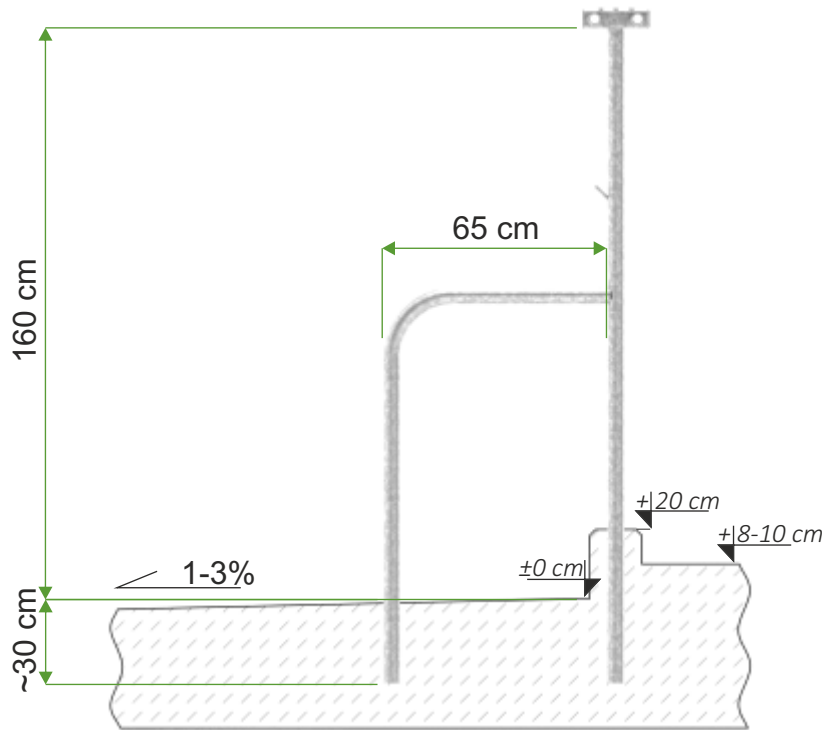
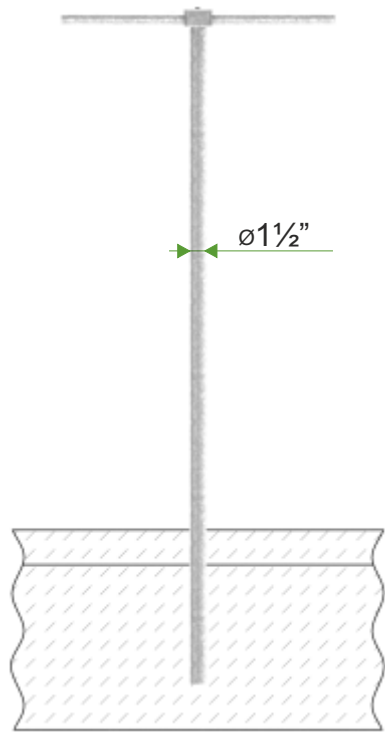

- 1 **W10-01-03** Tie-Stall IA HDG set
 - 2 **T08-10-040** Tube 33,7 x 2,6 (1") HDG m
- HDG - anti-corrosion protection - hot-dip galvanized
* - Screws M10x80 (2 psc) - not included in set.



TIE-STALL IAR

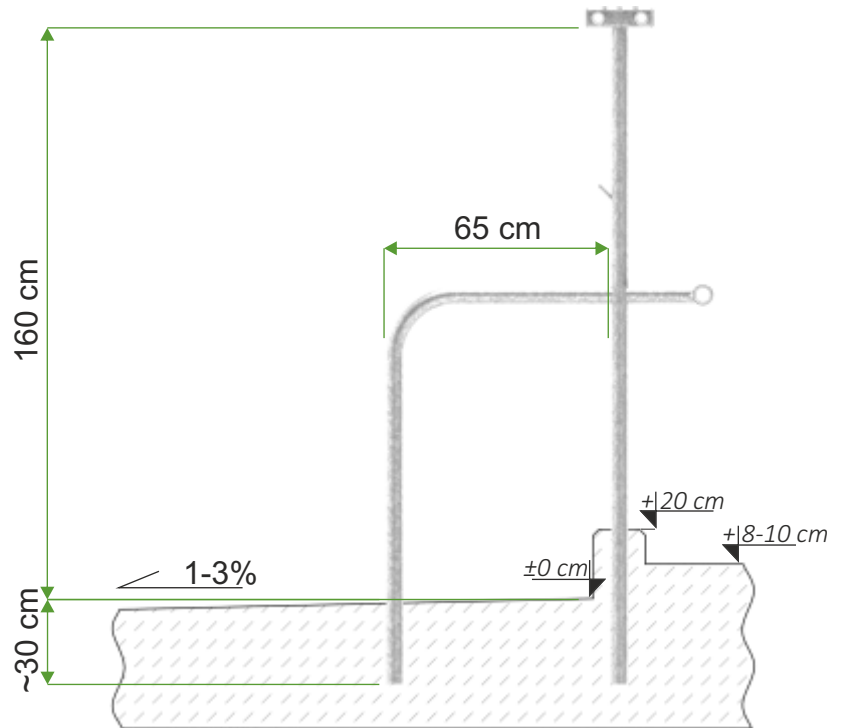
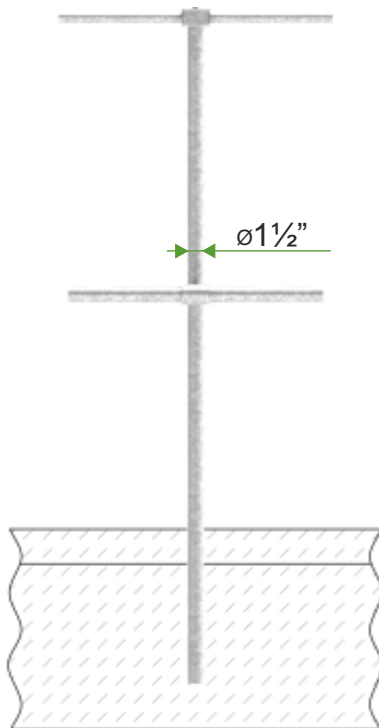
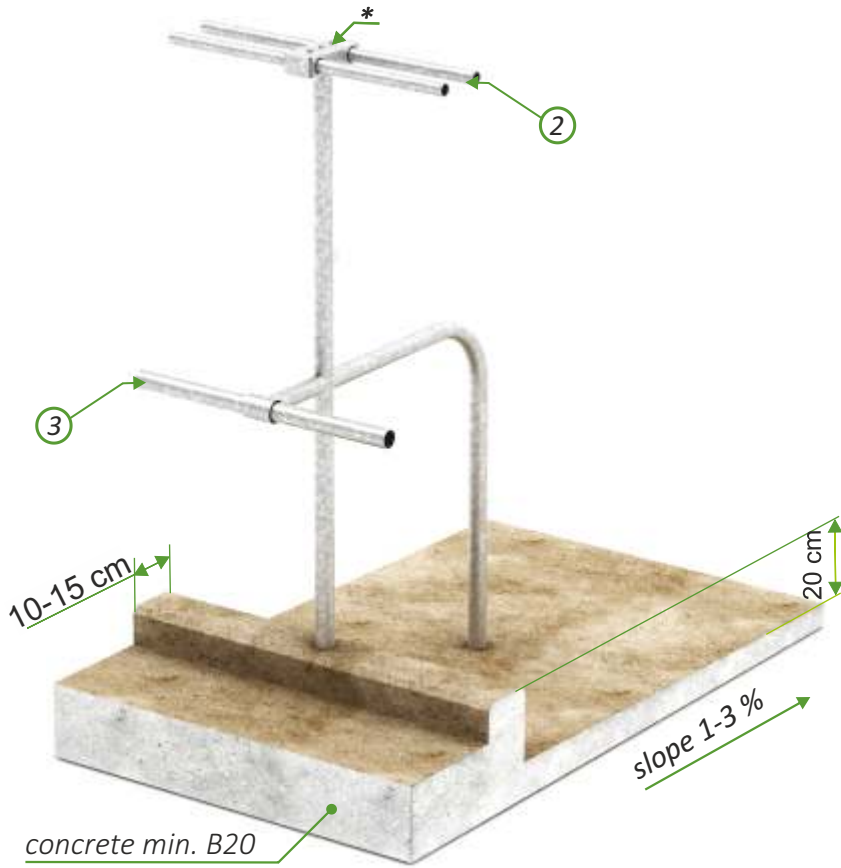

- | | | | |
|---|-------------------|--------------------------------|-----|
| 1 | W10-06-52 | Tie-Stall IAR HDG | set |
| 2 | T08-10-040 | Tube 33,7 x 2,6 (1") HDG | m |
| 3 | T08-10-050 | Tube 48,3 x 3,2 (1 1/2") HDG | m |

HDG - anti-corrosion protection - hot-dip galvanized

* - Screws M10x80 (2 psc) - not included in set.



TIE-STALL IIA

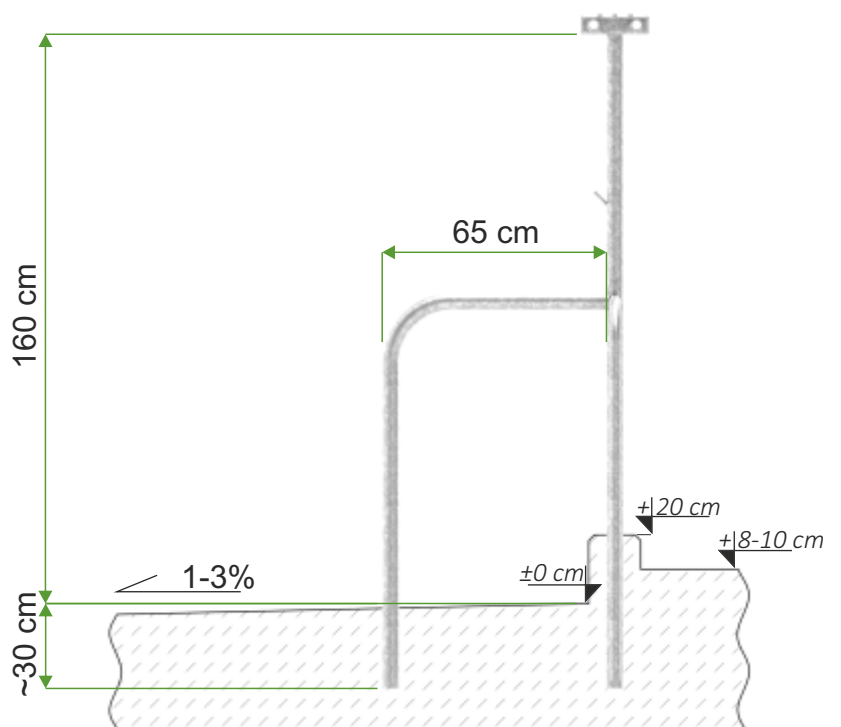
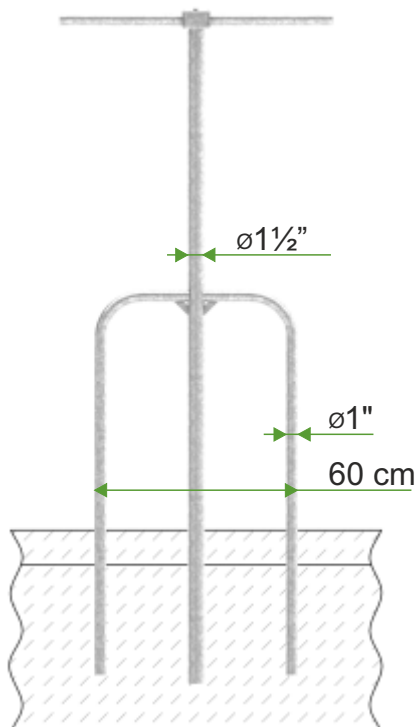

- | | | | |
|---|-------------------|----------------------------|-----|
| 1 | W10-01-12 | Tie-Stall IIA HDG | set |
| 2 | W10-01-17 | Tie-Stall IIA L HDG | set |
| 3 | W10-01-17 | Tie-Stall IIA P HDG | set |
| 4 | T08-10-040 | Tube 33,7 x 2,6 (1") HDG | m |

HDG - anti-corrosion protection - hot-dip galvanized

* - Screws M10x80 (2 psc) - not included in set.



TIE-STALL IIAR

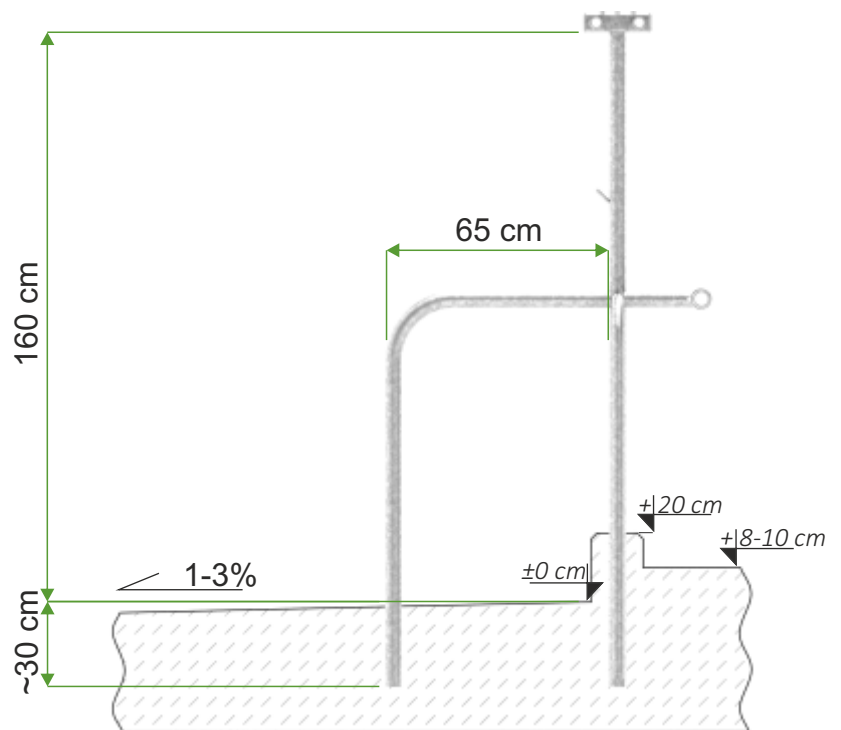
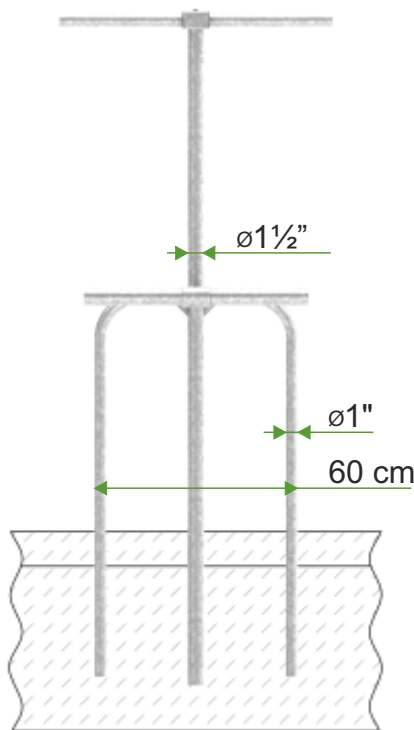
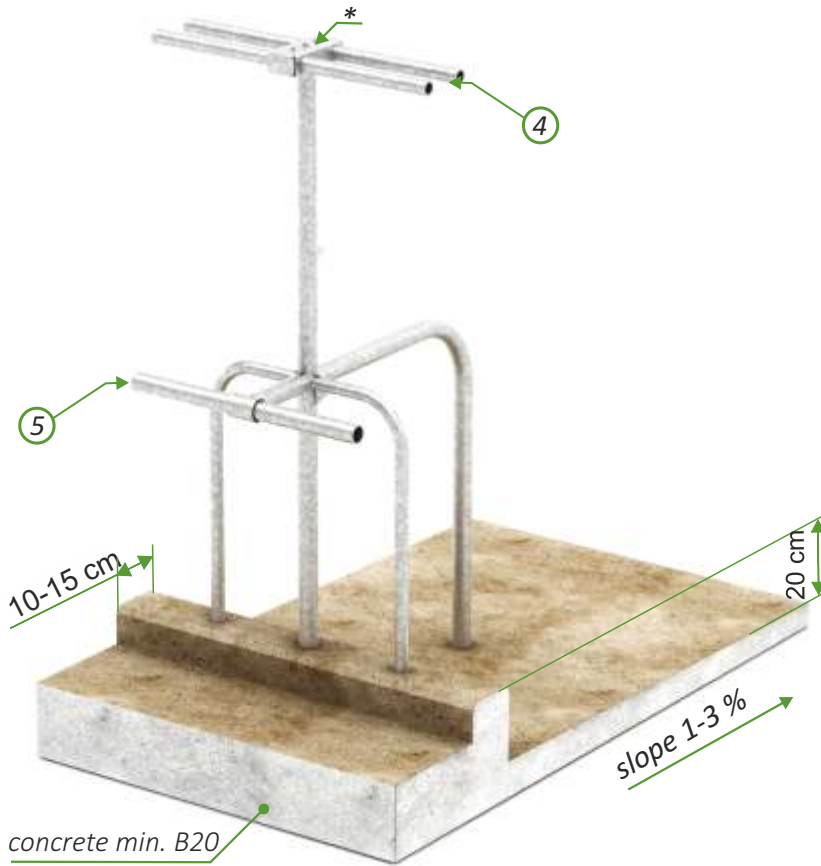

- | | | | |
|---|-------------------|--------------------------------|-----|
| 1 | W10-06-55 | Tie-Stall IIAR HDG | set |
| 2 | W10-06-58 | Tie-Stall IIAR L HDG | set |
| 3 | W10-06-58 | Tie-Stall IIAR P. HDG | set |
| 4 | T08-10-040 | Tube 33,7 x 2,6 (1") HDG | m |
| 5 | T08-10-050 | Tube 48,3 x 3,2 (1 1/2") HDG | m |

HDG - anti-corrosion protection - hot-dip galvanized

* - Screws M10x80 (2 pcs) - not included in set.



TIE-STALL VIA

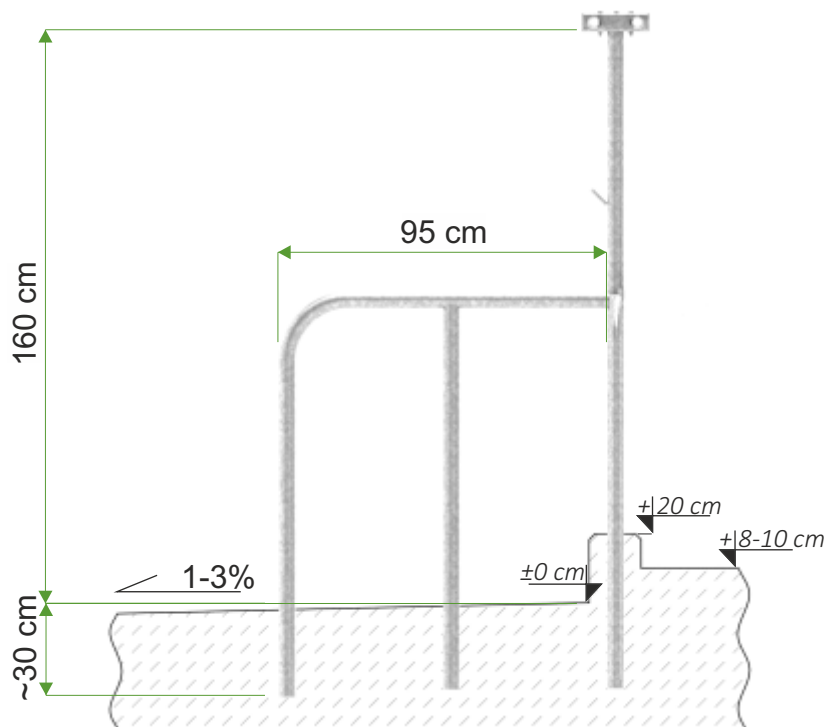
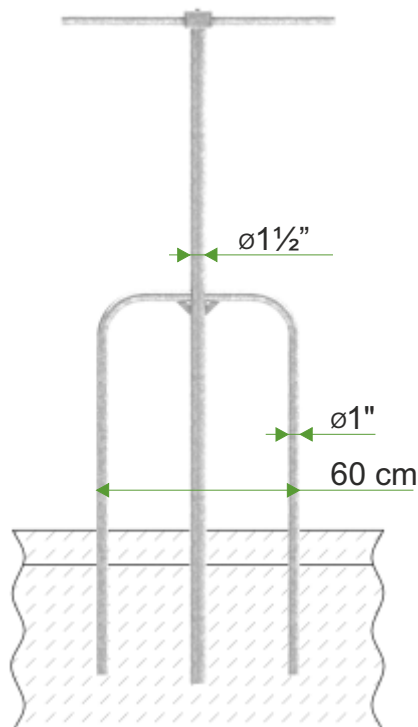
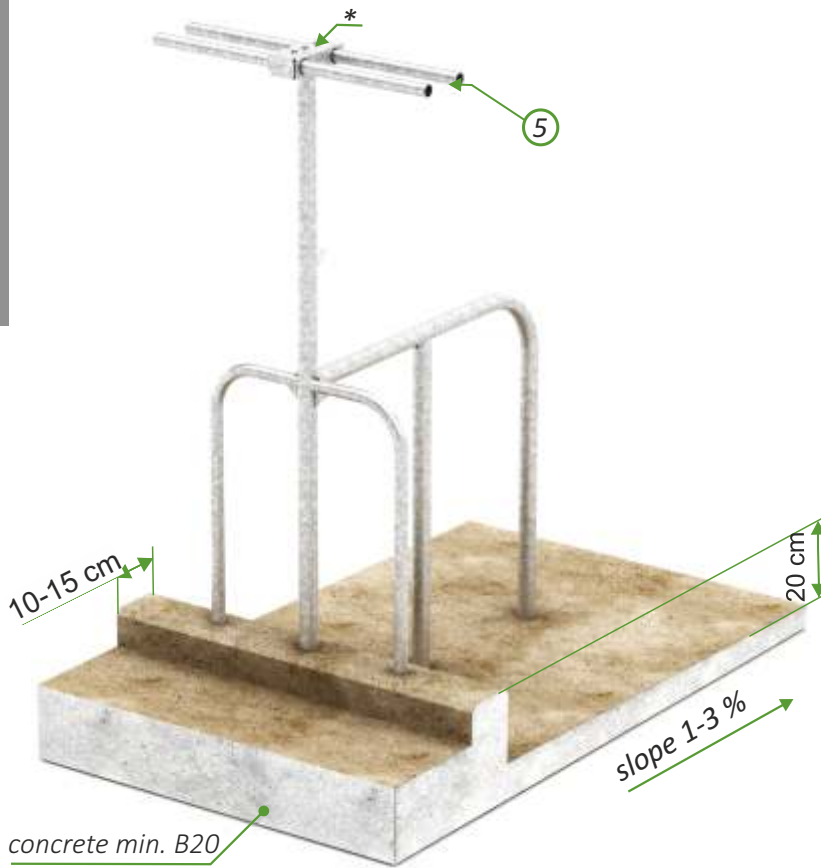

- | | | | |
|---|-------------------|---------------------------|-----|
| 1 | W10-01-47 | Tie-Stall VIA P+L HDG | set |
| 2 | W10-01-52 | Tie-Stall VIA L HDG | set |
| 3 | W10-01-52 | Tie-Stall VIA P HDG | set |
| 4 | W10-01-42 | Tie-Stall VIA HDG | set |
| 5 | T08-10-040 | Tube 33,7 x 2,6 (1") HDG | m |

HDG - anti-corrosion protection - hot-dip galvanized

* - Screws M10x80 (2 psc) - not included in set.



TIE-STALL VIAR

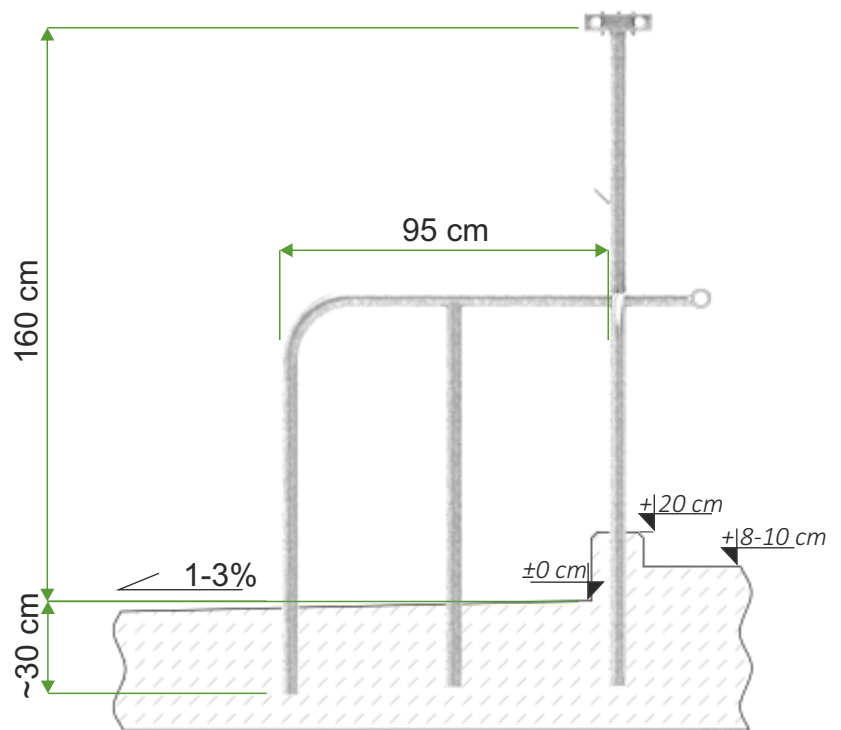
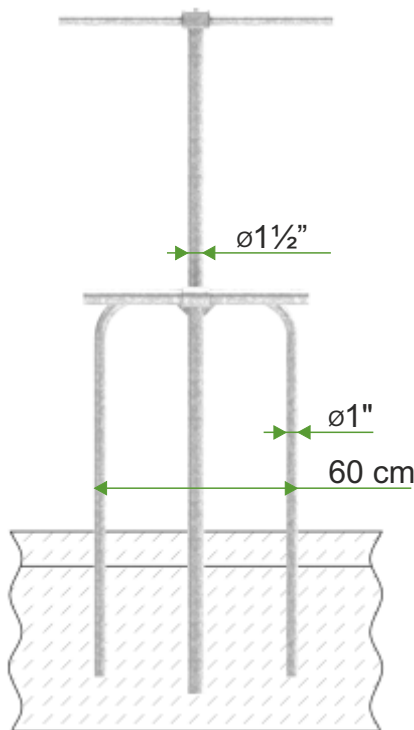
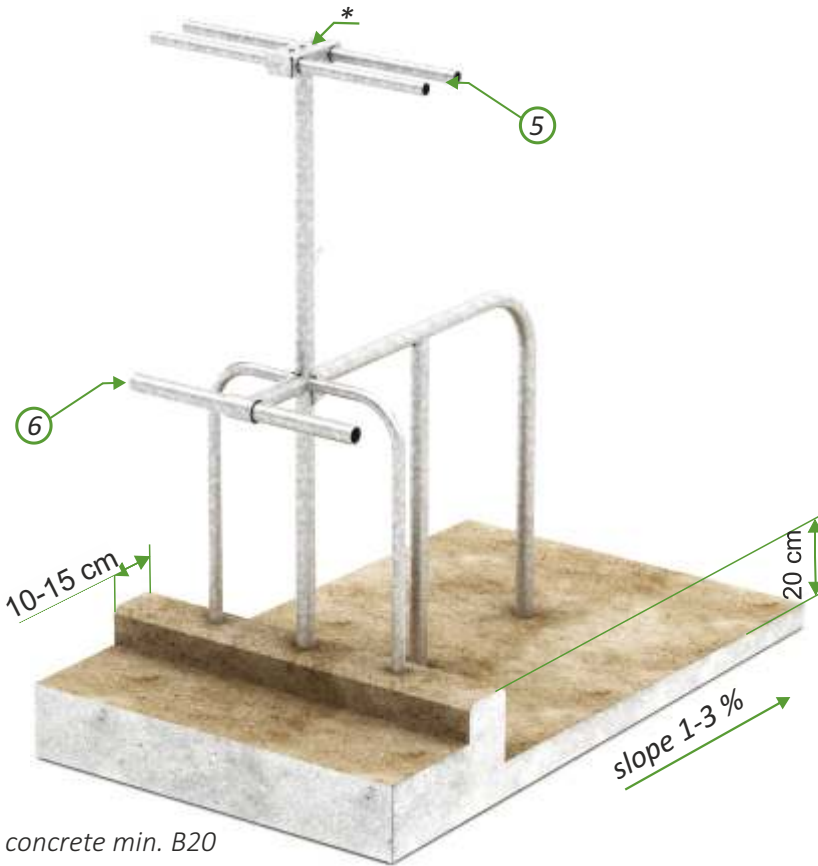

- | | | | |
|---|-------------------|-------------------------------|-----|
| 1 | W10-06-62 | Tie-Stall VIAR P+L HDG | set |
| 2 | W10-06-63 | Tie-Stall VIAR L HDG | set |
| 3 | W10-06-63 | Tie-Stall VIAR P HDG | set |
| 4 | W10-06-60 | Tie-Stall VIAR HDG | set |
| 5 | T08-10-040 | Tube 33,7 x 2,6 (1") HDG | m |
| 6 | T08-10-050 | Tube 48,3 x 3,2 (1 1/2") HDG | m |

HDG - anti-corrosion protection - hot-dip galvanized

* - Screws M10x80 (2 psc) - not included in set.



TIE-STALL TYPE B

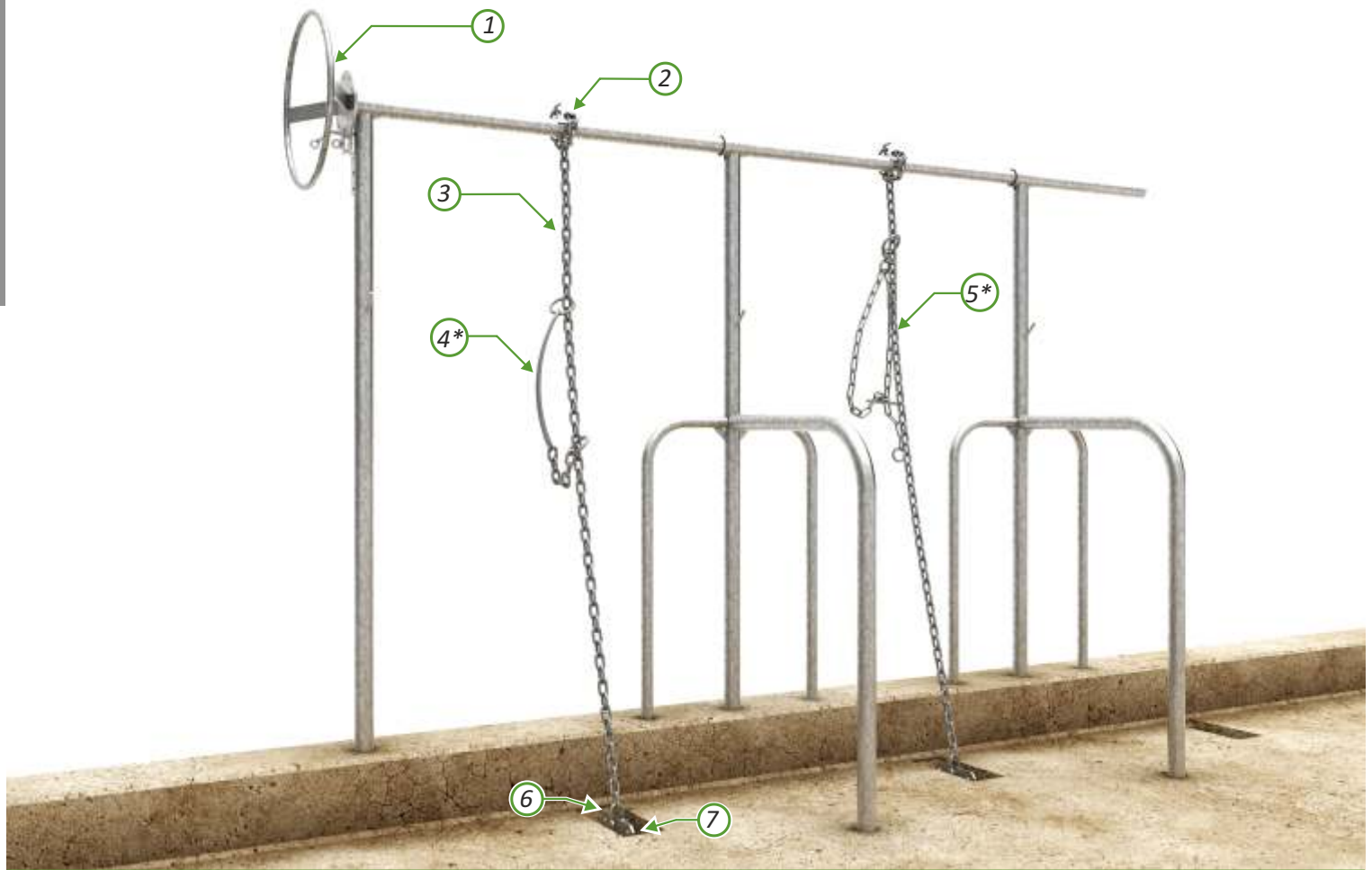

* to choose joke (4*) or chain braket (5*)

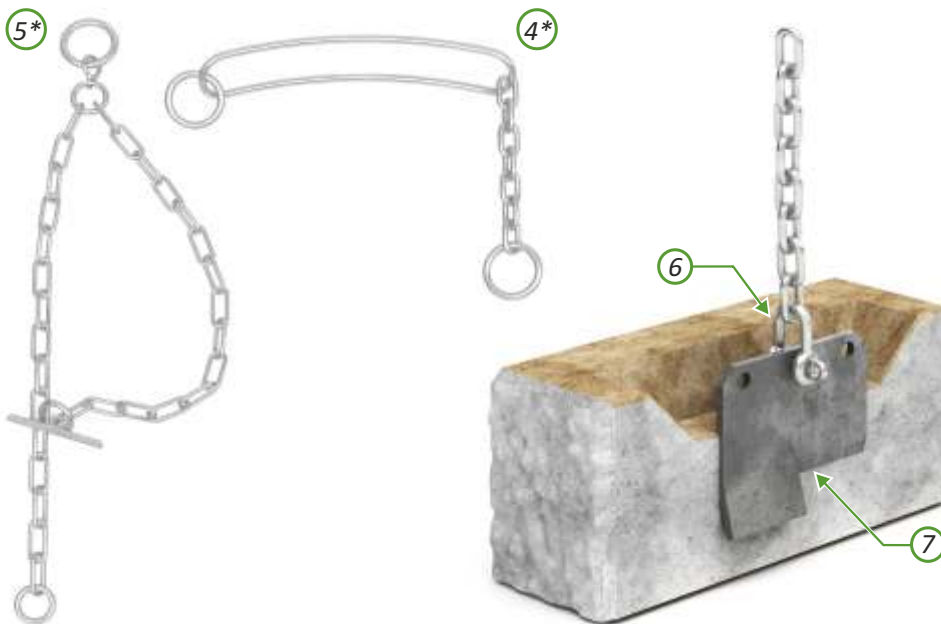

Wheel releaser type B



Tie hook type B

1	W10-03-21	Whele releaser B HDG	pcs
2	W10-03-02	Tie hook B HDG	pcs
3	W10-03-26	Vertical chain type B HDG	pcs
4	W10-03-16	Joke HDG	pcs
5	W10-03-06	Chain braket HDG	pcs
6	T33-05-01	Schackle M 10	pcs
7	W10-03-10	Anchor HDG	pcs

HDG - anti-corrosion protection - hot-dip galvanized.



SYSTEM ELEMENTS

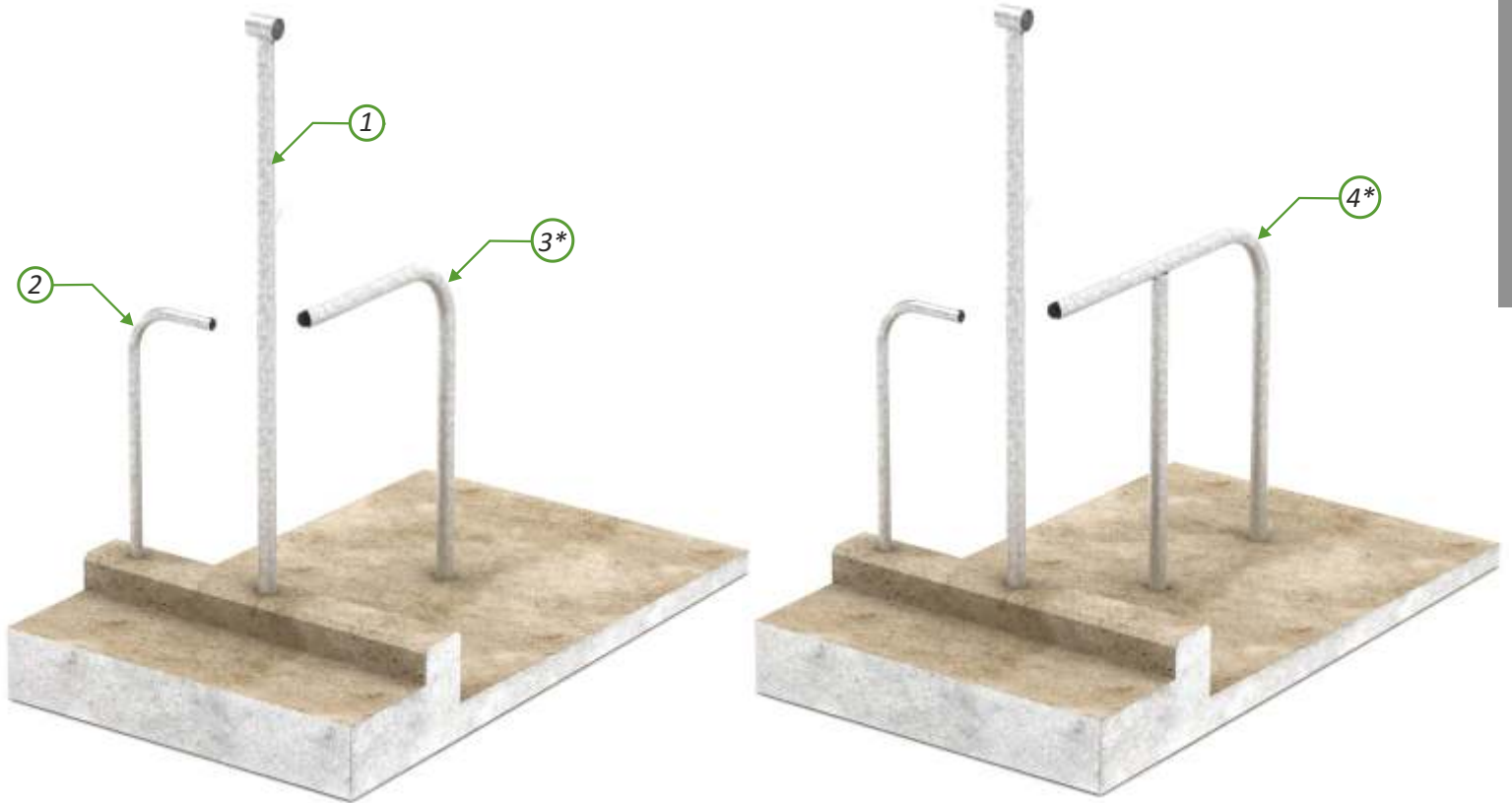

3*, 4* - two types of tie-stall rear arches curves to choose

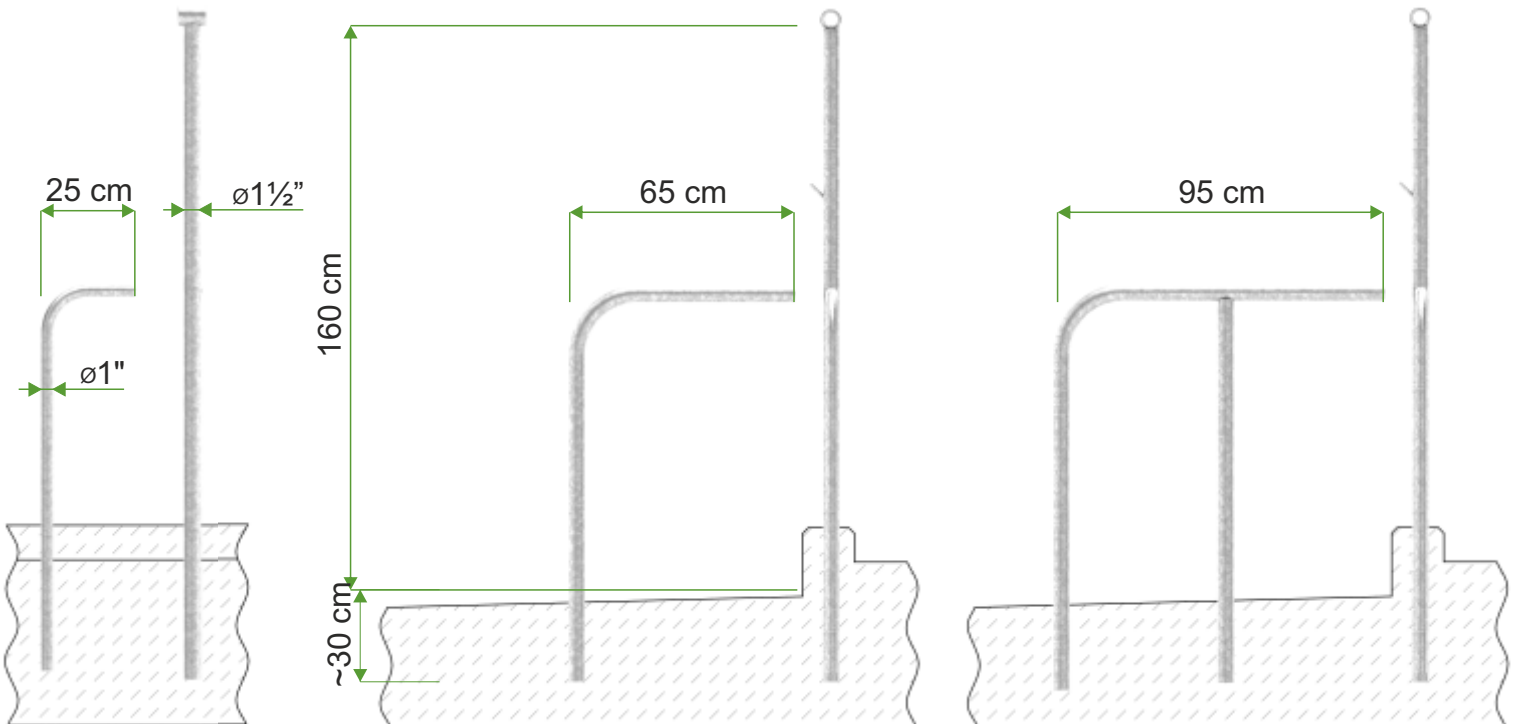

- | | | | |
|---|------------------|------------------------------------|-----|
| 1 | W10-02-27 | Steel post to Tie-Stall type B HDG | set |
| 2 | W10-02-32 | Tie-Stall side steel arch HDG | set |
| 3 | W10-02-37 | Tie-Stall rear steel arch HDG | set |
| 4 | W10-02-43 | Tie -Stall rear steel arch VI HDG | set |
- HDG - anti-corrosion protection - hot-dip galvanized.



TIE-STALL IB

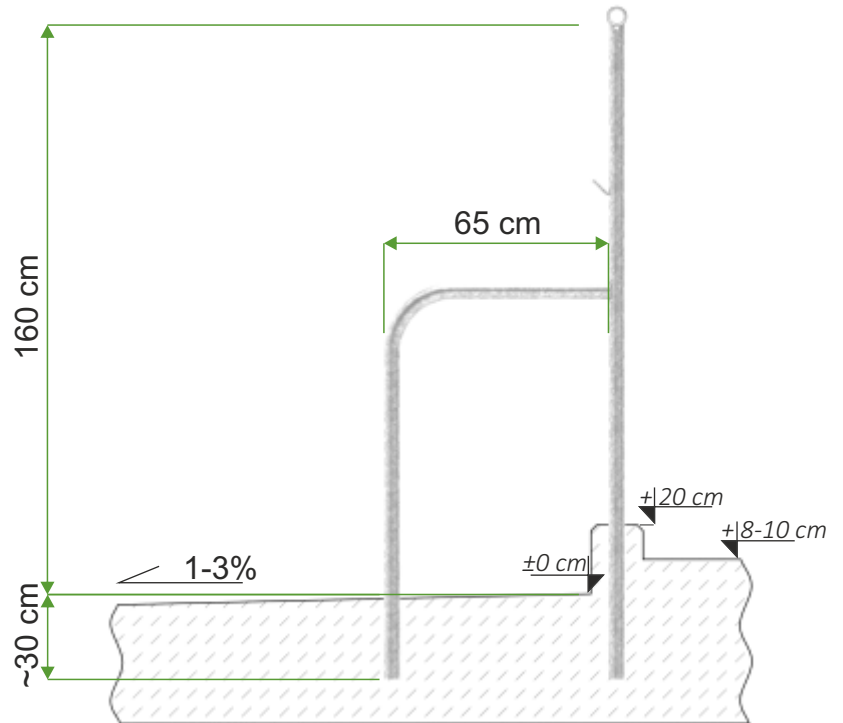
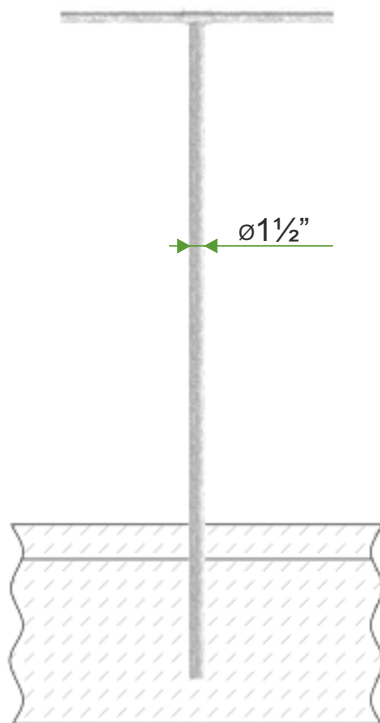
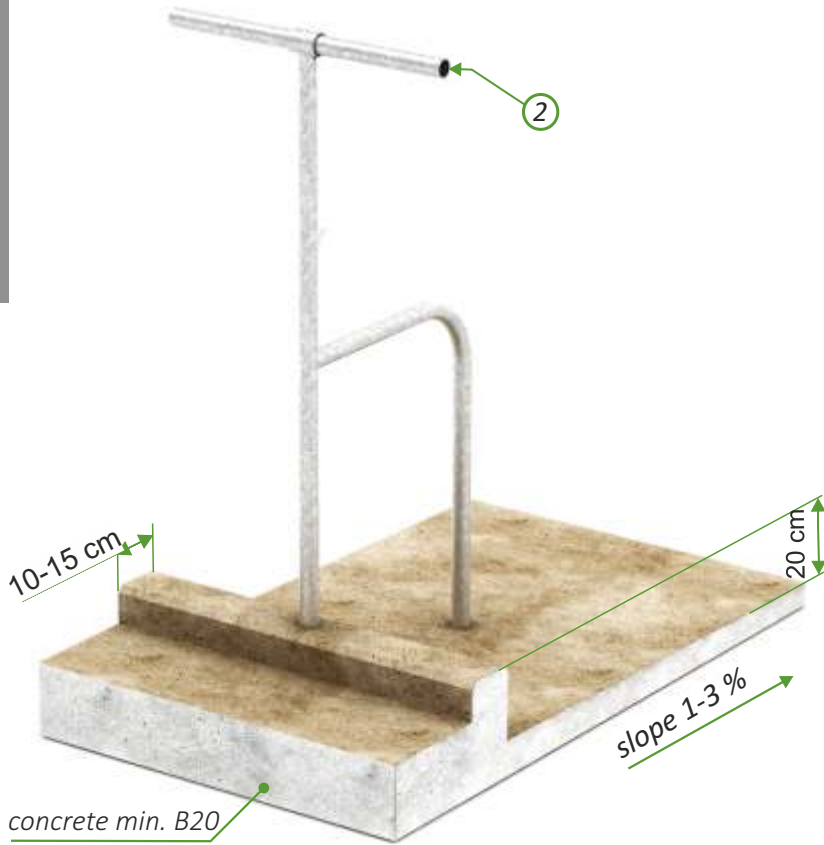

- | | | | |
|---|-------------------|--------------------------------|-----|
| 1 | W10-01-07 | Tie-Stall IB HDG | pcs |
| 2 | T08-10-050 | Tube 48,3 x 3,2 (1 1/2") HDG | m |
- HDG - anti-corrosion protection - hot-dip galvanized.



TIE-STALL IBR

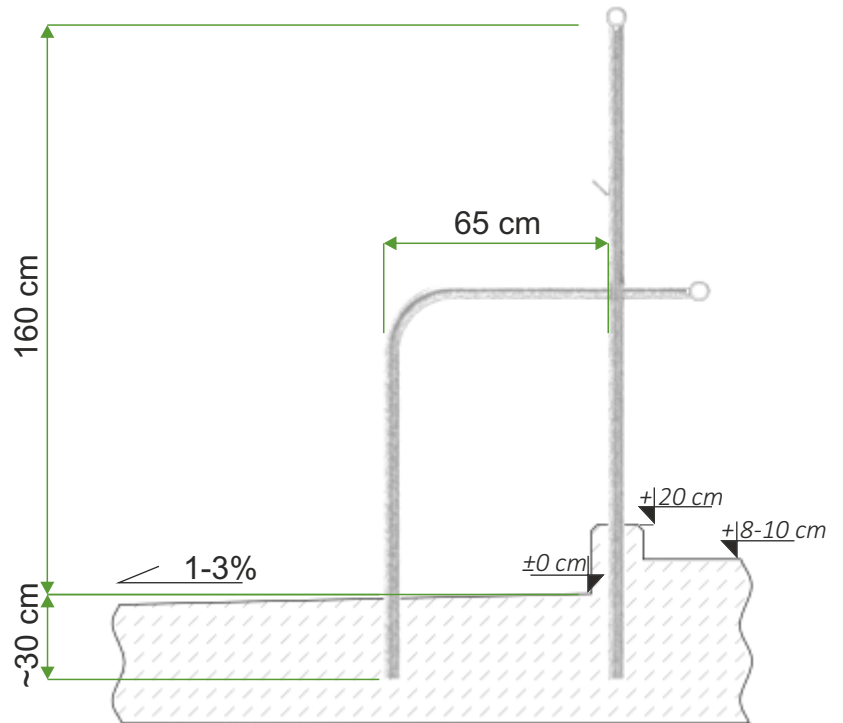
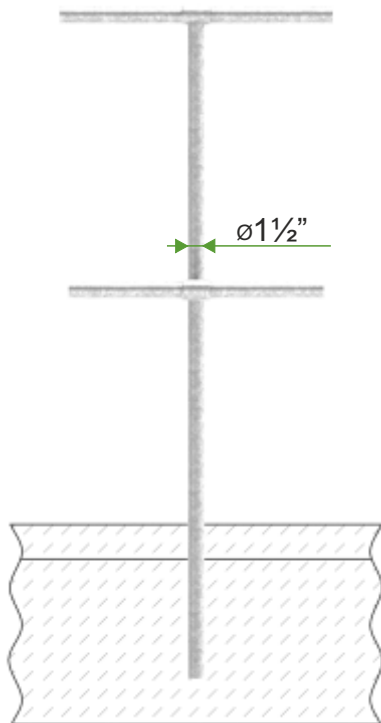
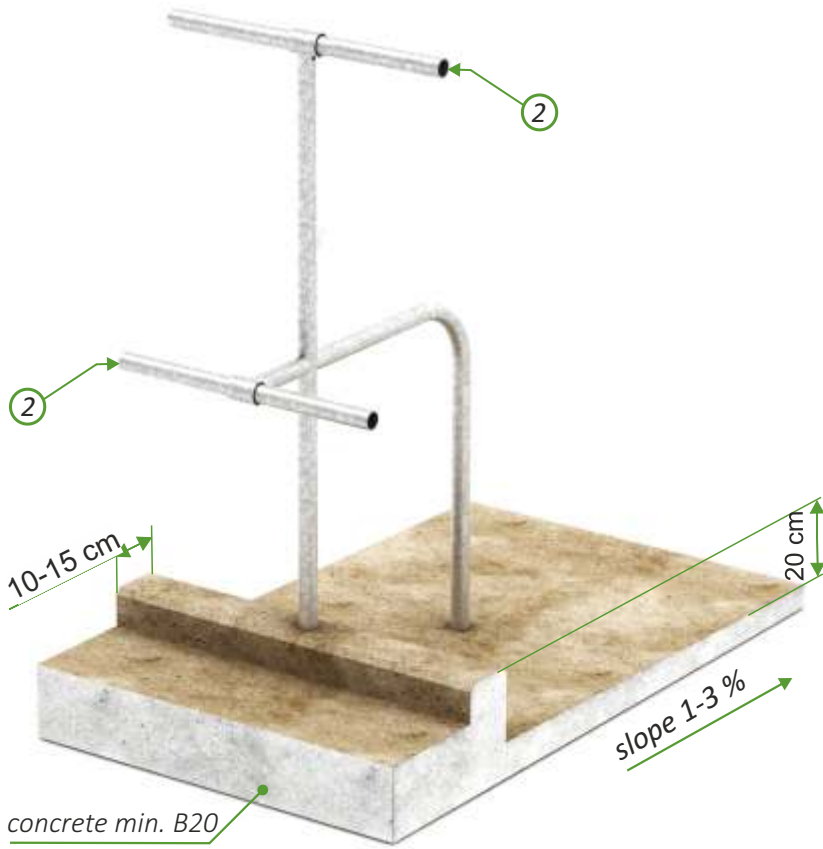

- | | | | |
|---|-------------------|-------------------------------|-----|
| 1 | W10-06-03 | Tie-Stall IBR HDG | pcs |
| 2 | T08-10-050 | Tube 48,3 x 3,2 (1 1/2") HDG | m |
- HDG - anti-corrosion protection - hot-dip galvanized.



TIE-STALL IBW

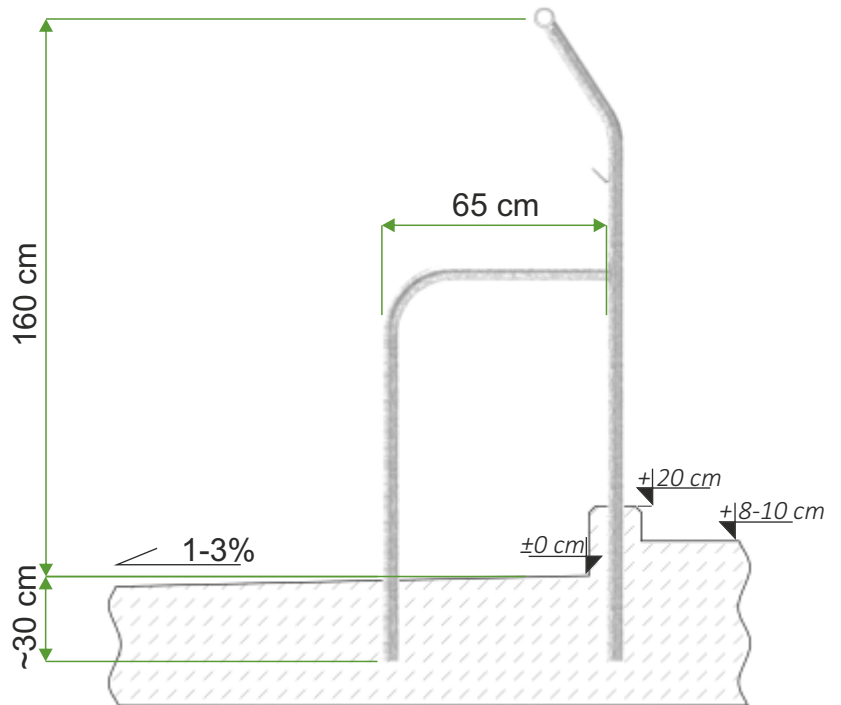
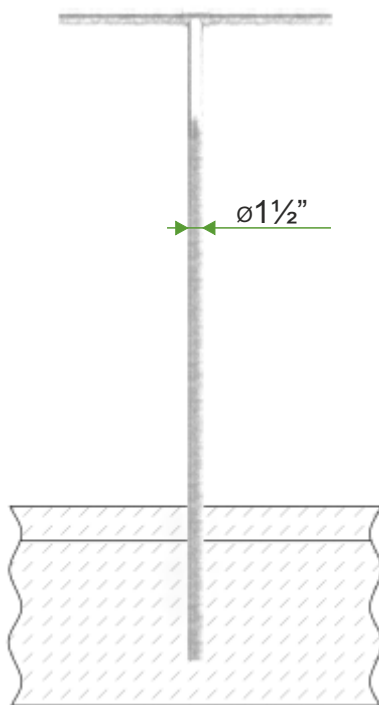
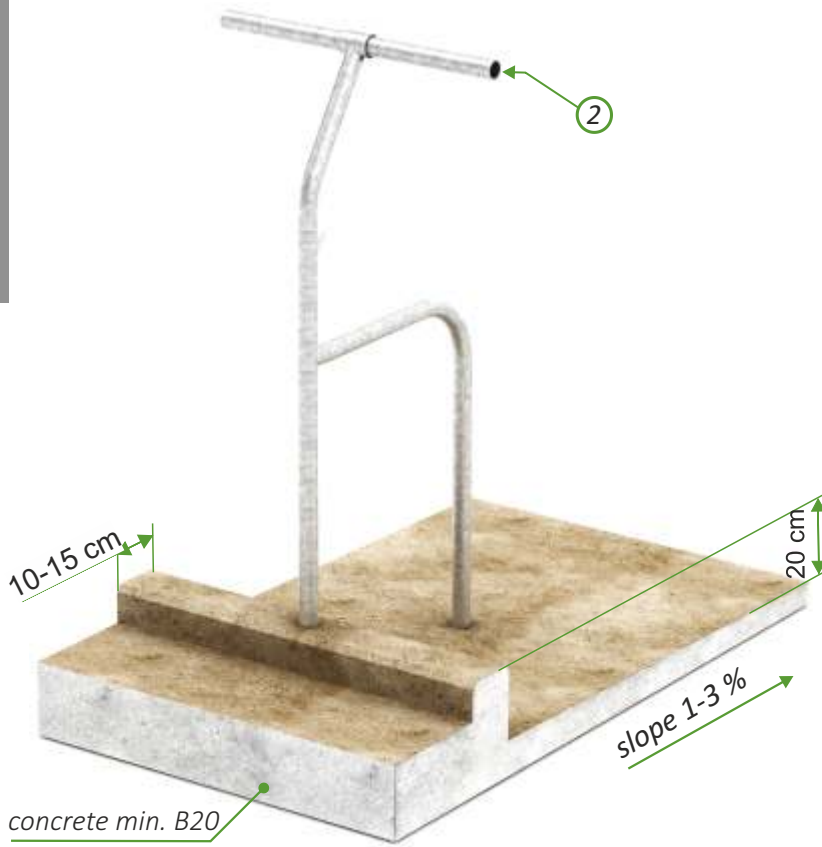

- | | | | |
|---|-------------------|--------------------------------|-----|
| 1 | W10-06-06 | Tie-Stall IBW HDG | pcs |
| 2 | T08-10-050 | Tube 48,3 x 3,2 (1 1/2") HDG | m |
- HDG - anti-corrosion protection - hot-dip galvanized.



TIE-STALL IIB

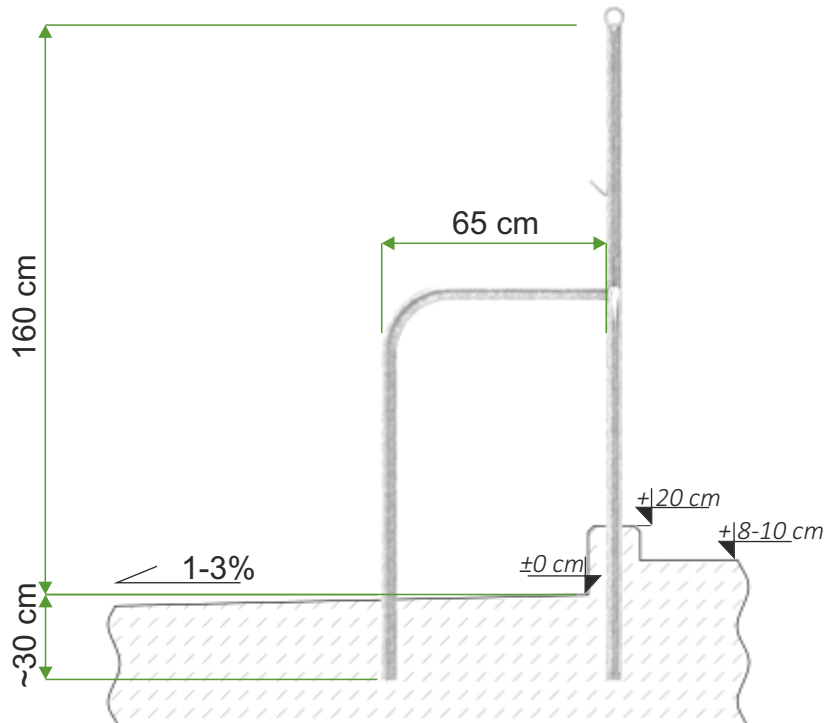
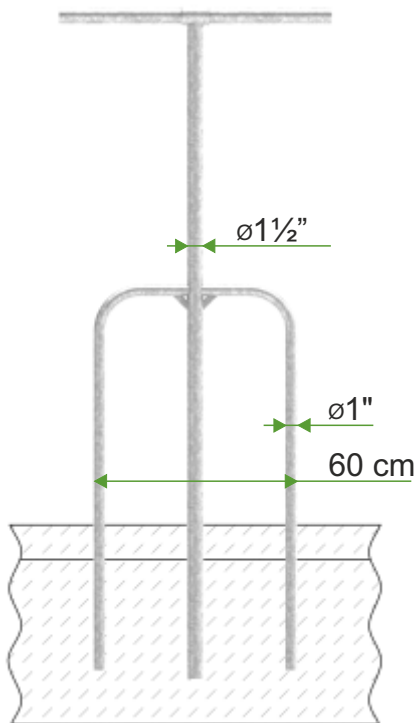
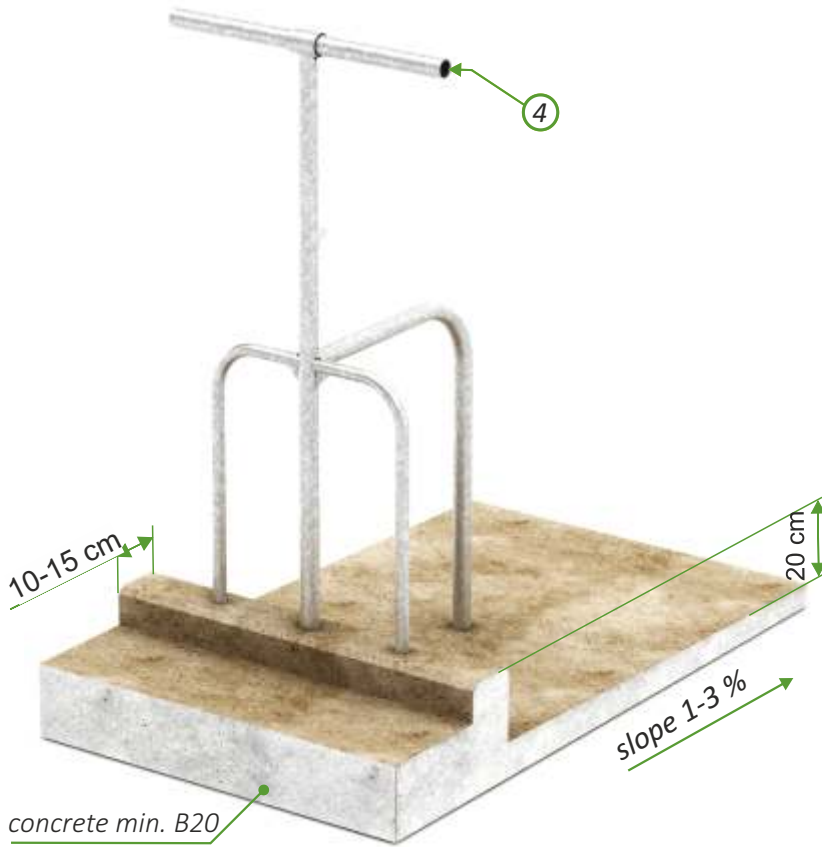

- | | | | |
|---|-------------------|-------------------------------|-----|
| 1 | W10-01-22 | Tie-Stall IIB HDG | pcs |
| 2 | W10-01-27 | Tie-Stall IIB L HDG | pcs |
| 3 | W10-01-27 | Tie-Stall IIB P HDG | pcs |
| 4 | T08-10-050 | Tube 48,3 x 3,2 (1 1/2") HDG | m |
- HDG - anti-corrosion protection - hot-dip galvanized.



TIE-STALL IIBR

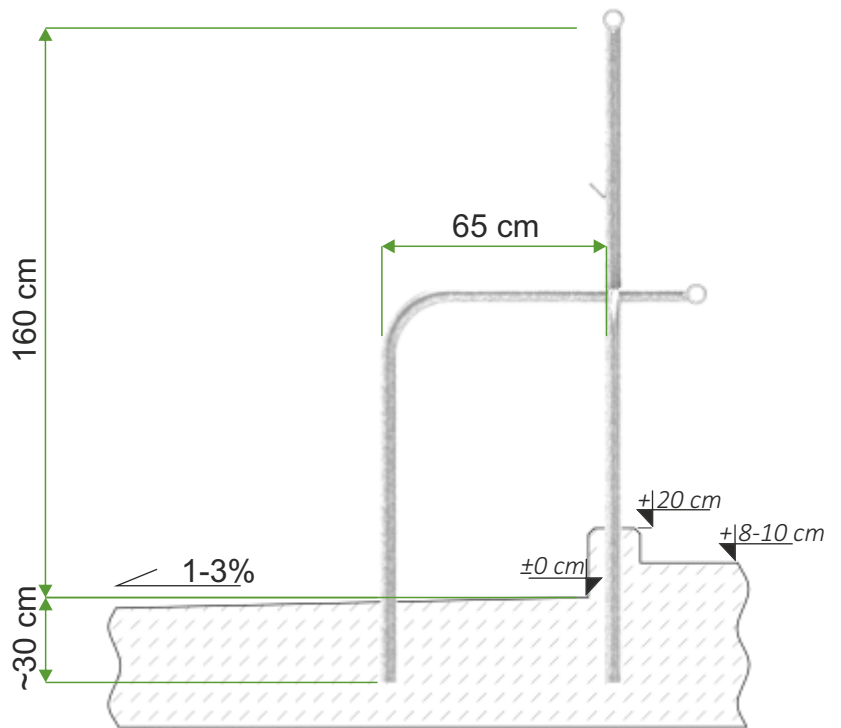
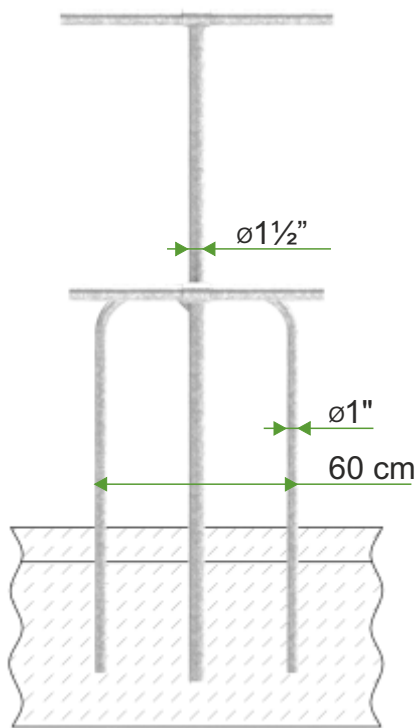
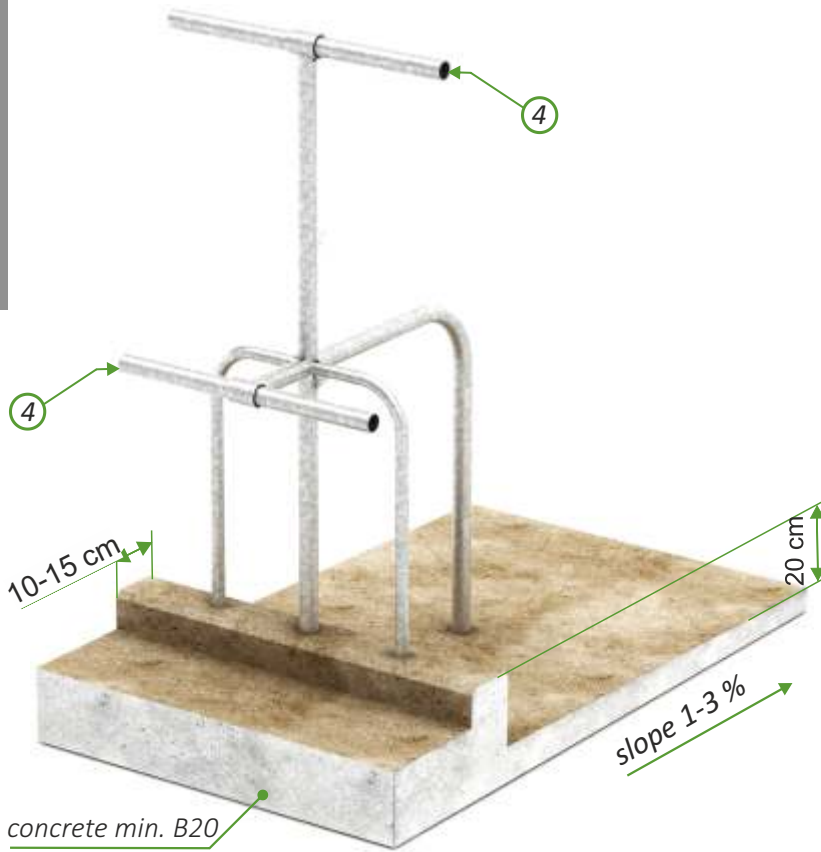

- | | | | |
|---|-------------------|--------------------------------|-----|
| 1 | W10-06-09 | Tie-Stall IIBR HDG | set |
| 2 | W10-06-12 | Tie-Stall IIBR L HDG | set |
| 3 | W10-06-12 | Tie-Stall IIBR P HDG | set |
| 4 | T08-10-050 | Tube 48,3 x 3,2 (1 1/2") HDG | m |
- HDG - anti-corrosion protection - hot-dip galvanized.



TIE-STALL IIBW

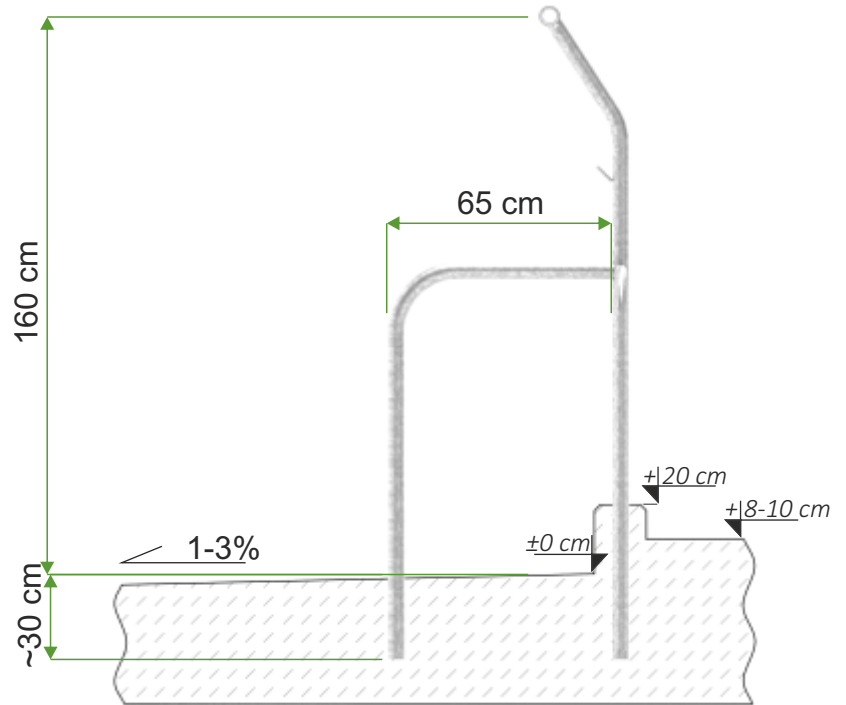
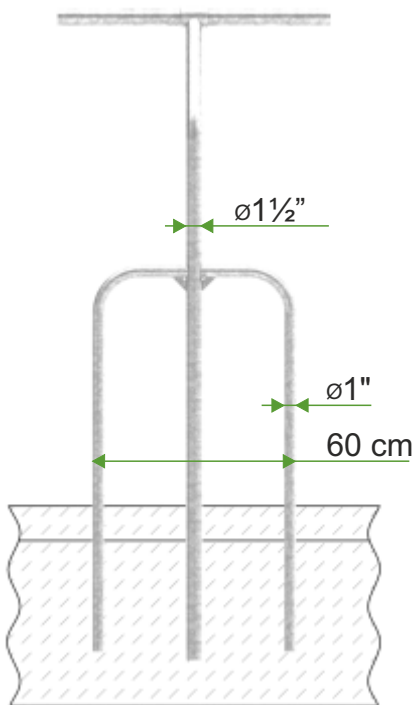
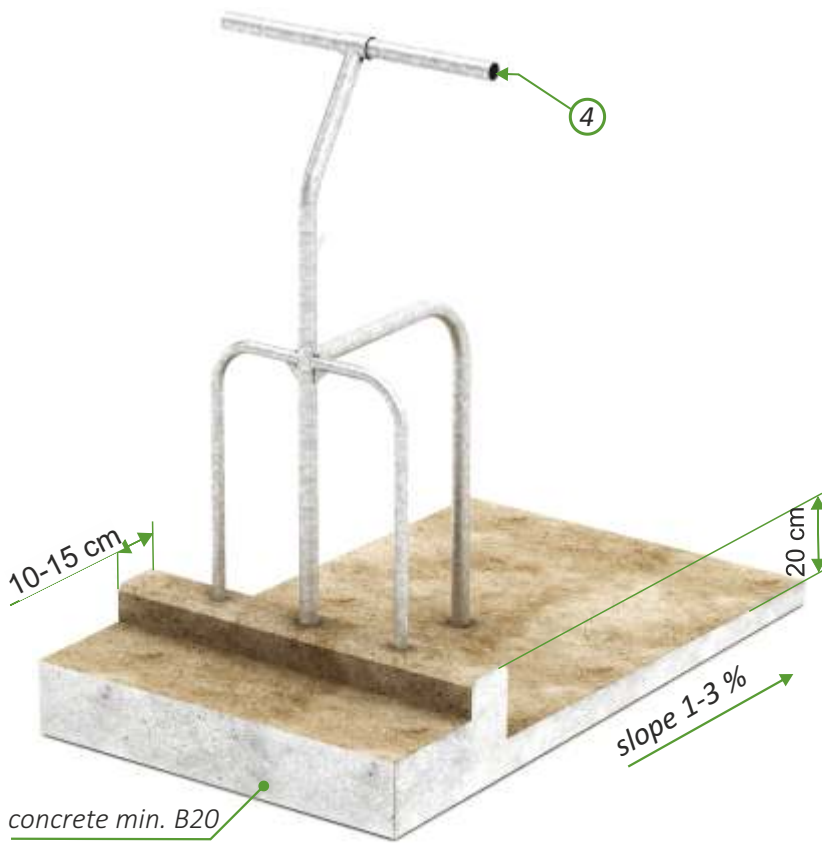

- | | | | |
|---|-------------------|--------------------------------|-----|
| 1 | W10-06-15 | Tie-Stall IIBW HDG | set |
| 2 | W10-06-18 | Tie-Stall IIBW L HDG | set |
| 3 | W10-06-18 | Tie-Stall IIBW P HDG | set |
| 4 | T08-10-050 | Tube 48,3 x 3,2 (1 1/2") HDG | m |
- HDG - anti-corrosion protection - hot-dip galvanized.



TIE-STALL VIB

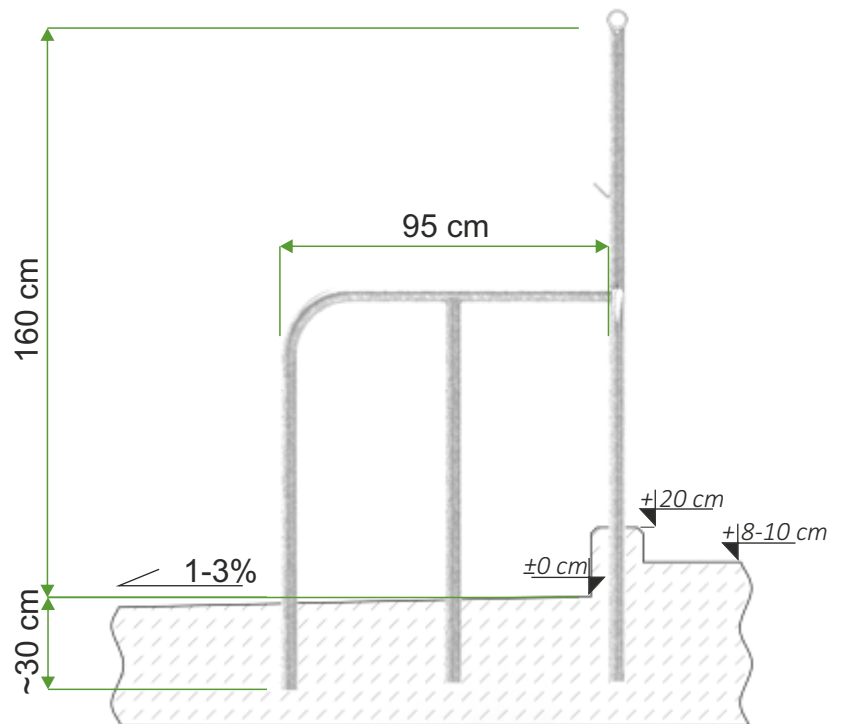
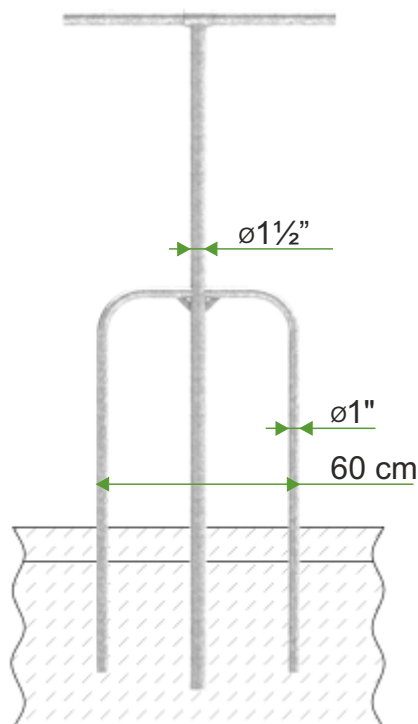
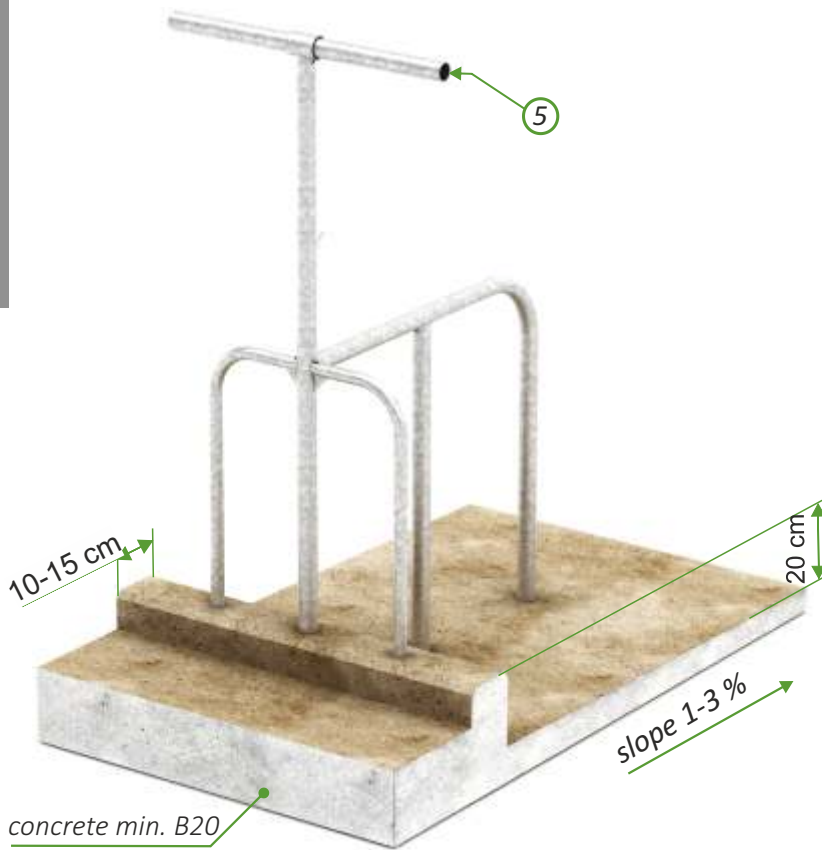

- | | | | |
|---|-------------------|-------------------------------|-----|
| 1 | W10-01-62 | Tie-Stall VIB P+L HDG | pcs |
| 2 | W10-01-67 | Tie-Stall VIB L HDG | pcs |
| 3 | W10-01-67 | Tie-Stall VIB P HDG | pcs |
| 4 | W10-01-57 | Tie-Stall VIB HDG | pcs |
| 5 | T08-10-050 | Tube 48,3 x 3,2 (1 1/2") HDG | m |
- HDG - anti-corrosion protection - hot-dip galvanized.



TIE-STALL VIBR

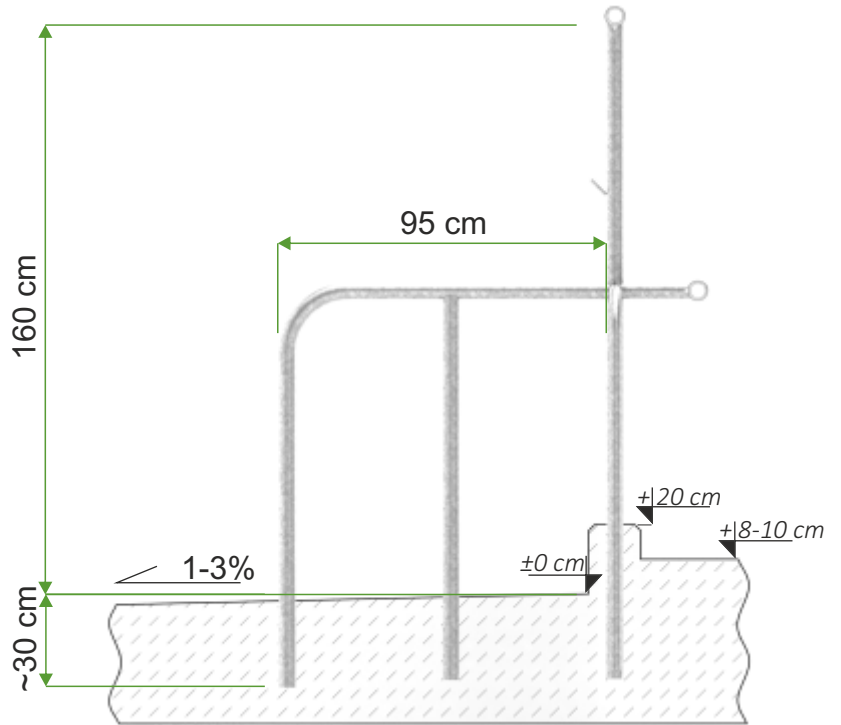
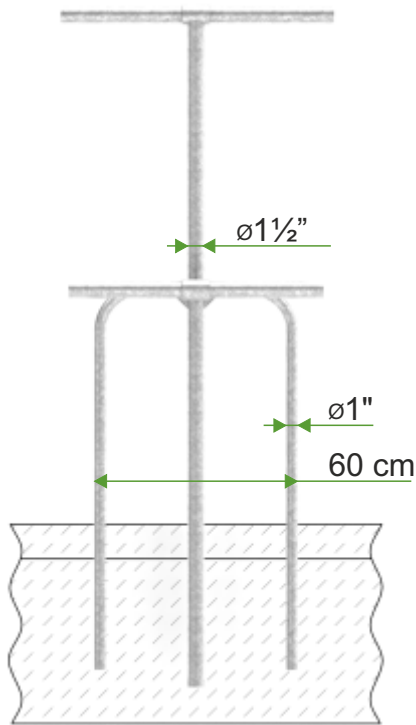
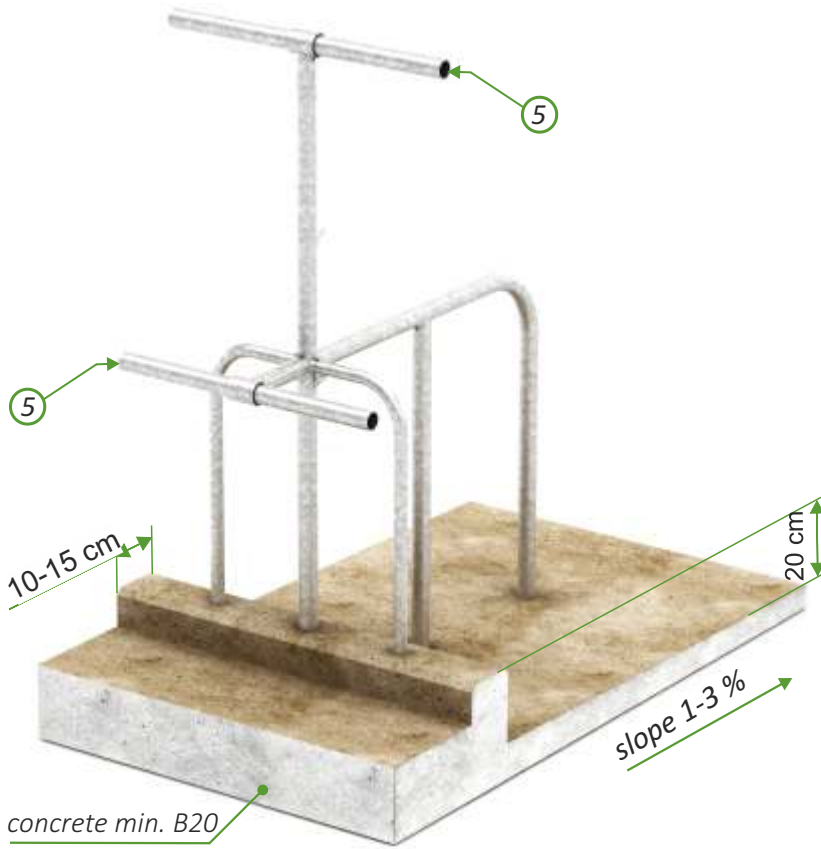

- | | | | |
|---|-------------------|-------------------------------|-----|
| 1 | W10-06-27 | Tie-Stall VIBR P+L HDG | set |
| 2 | W10-06-24 | Tie-Stall VIBR L HDG | set |
| 3 | W10-06-24 | Tie-Stall VIBR P HDG | set |
| 4 | W10-06-21 | Tie-Stall VIBR HDG | set |
| 5 | T08-10-050 | Tube 48,3 x 3,2 (1 1/2") HDG | m |
- HDG - anti-corrosion protection - hot-dip galvanized.



TIE-STALL VIBW

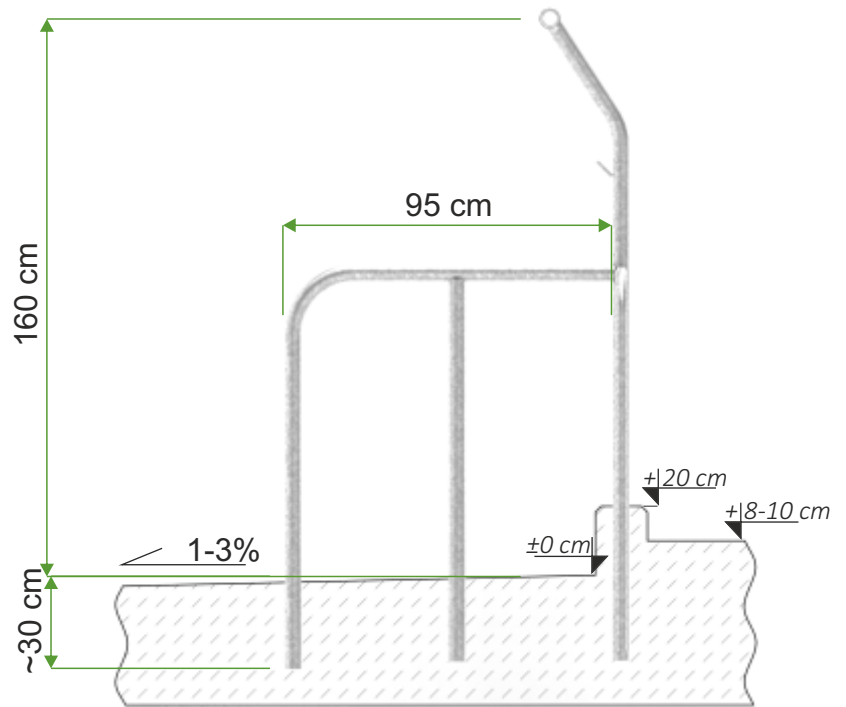
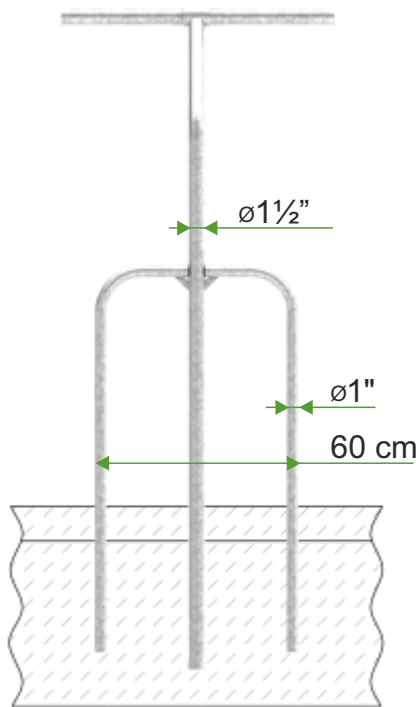
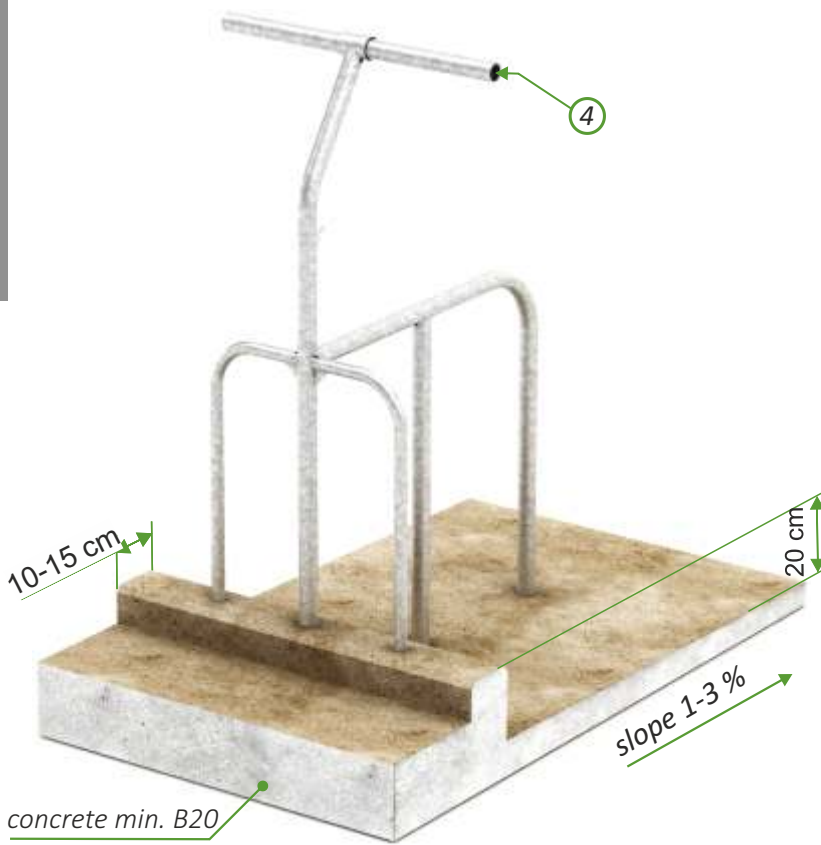

- | | | | |
|---|-------------------|-------------------------------|-----|
| 1 | W10-06-36 | Tie-Stall VIBW P+L HDG | set |
| 2 | W10-06-33 | Tie-Stall VIBW L HDG | set |
| 3 | W10-06-33 | Tie-Stall VIBW P HDG | set |
| 4 | W10-06-30 | Tie-Stall VIBW HDG | set |
| 5 | T08-10-050 | Tube 48,3 x 3,2 (1 1/2") HDG | m |

HDG - anti-corrosion protection - hot-dip galvanized.



TIE-STALL VIBWR

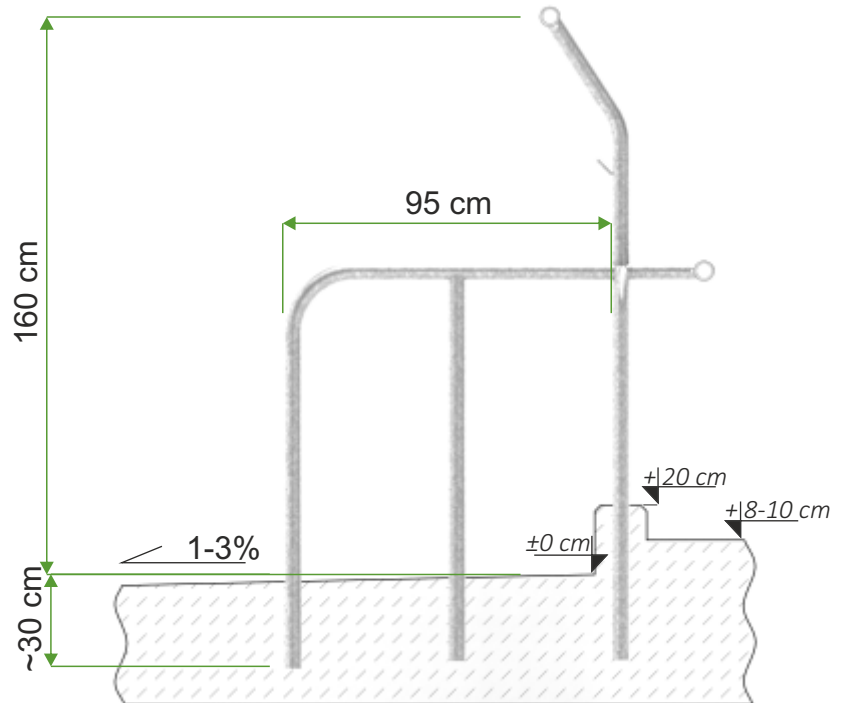
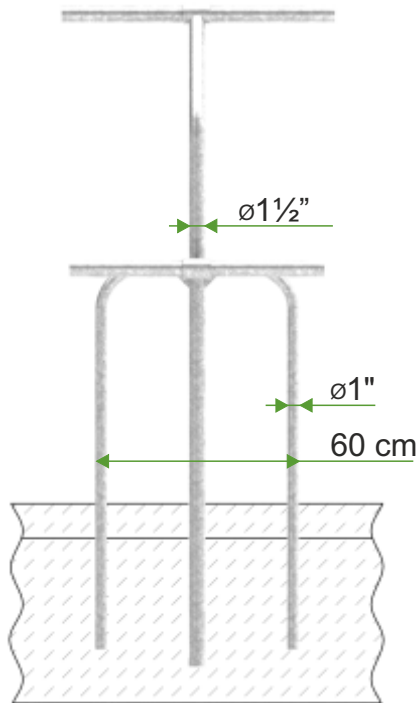
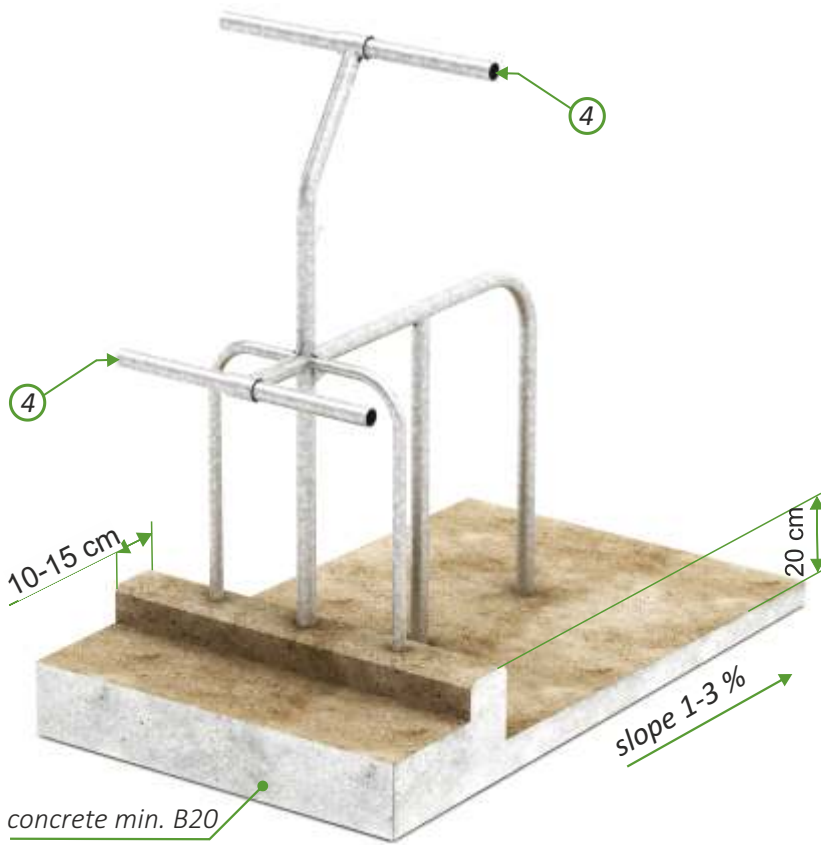

- | | | | |
|---|-------------------|-------------------------------|-----|
| 1 | W10-06-38 | Tie-Stall VIBWR P+L HDG | set |
| 2 | W10-06-37 | Tie-Stall VIBWR L HDG | set |
| 3 | W10-06-37 | Tie-Stall VIBWR P HDG | set |
| 4 | T08-10-050 | Tube 48,3 x 3,2 (1 1/2") HDG | m |
- HDG - anti-corrosion protection - hot-dip galvanized.



TIE-STALL VIII

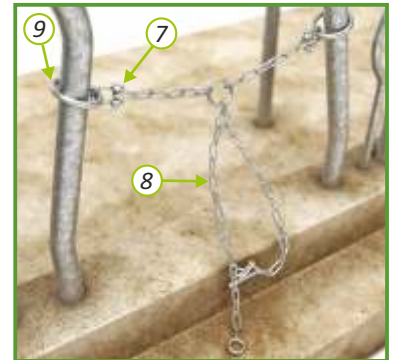
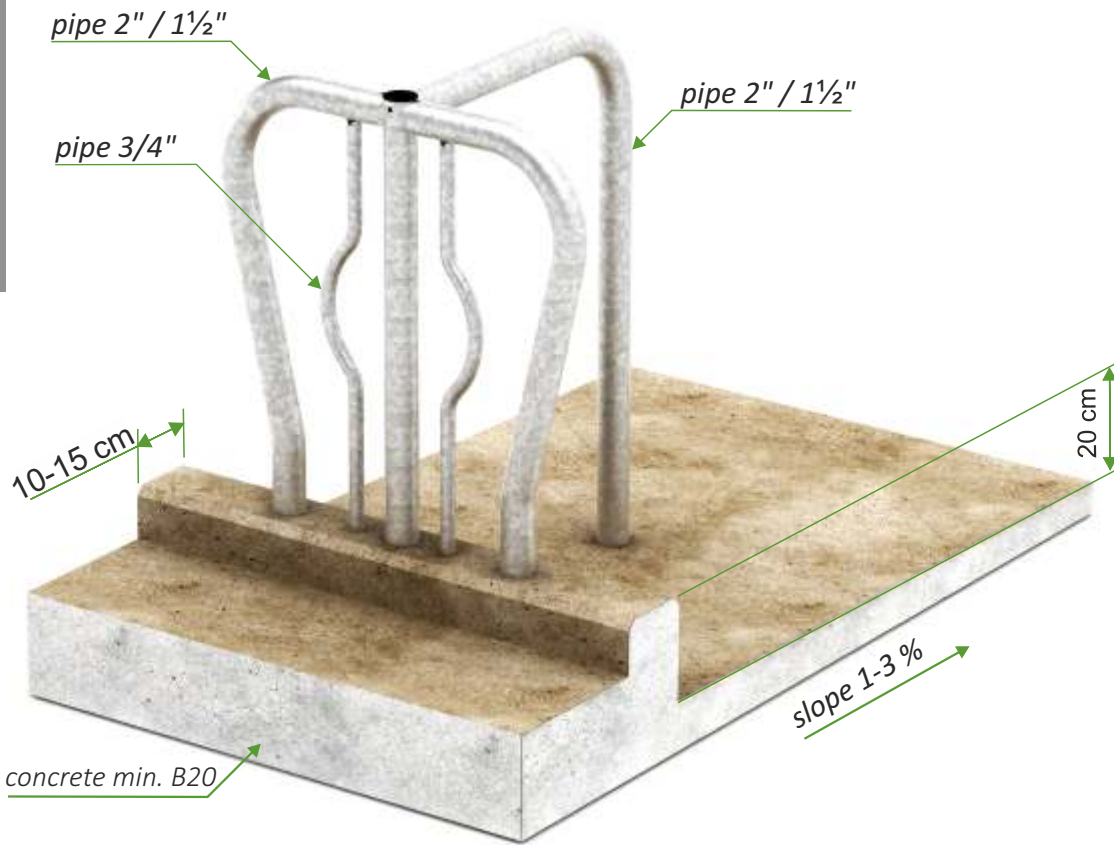

Tying type VIII



right



left

VERSION VIII-1 - PIPE 1 1/2" (48,3 mm)
VERSION VIII-2 - PIPE 2" (60,3 mm)

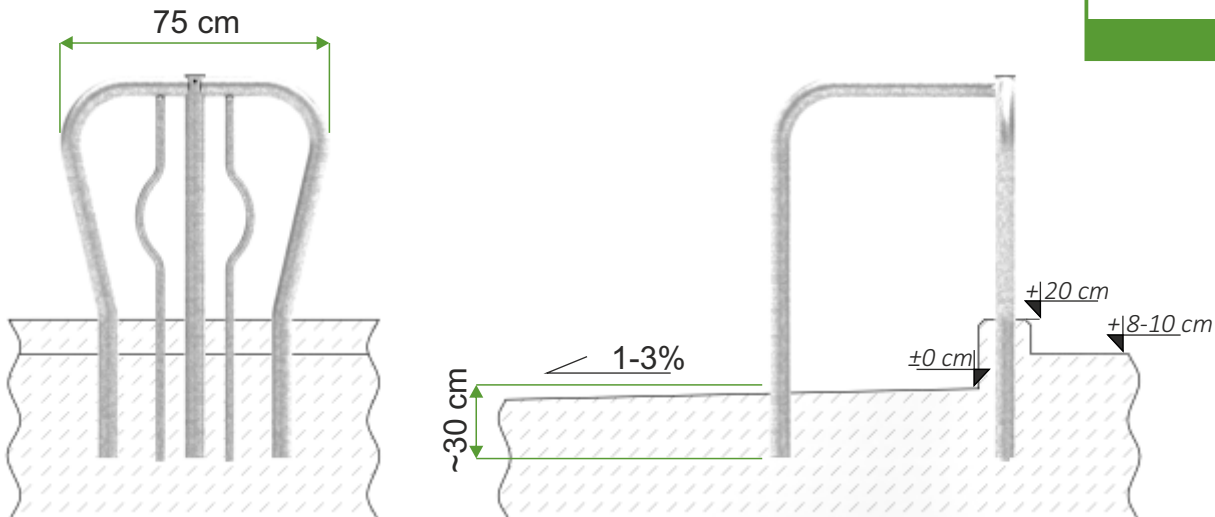

1	W10-01-77	Tie-Stall VIII - 1 HDG	pcs
2	W10-01-85	Tie-Stall VIII - 1 P HDG	pcs
3	W10-01-85	Tie-Stall VIII - 1 L HDG	pcs
4	W10-01-82	Tie-Stall VIII - 2 HDG	pcs
5	W10-01-88	Tie-Stall VIII - 2 P HDG	pcs
6	W10-01-88	Tie-Stall VIII - 2 L HDG	pcs
7	T33-05-01	Schackle M 10	pcs
8	W10-03-41	Chain type VIII HDG	pcs
9	W10-03-31	Tie-Stall ring HDG	pcs

HDG - anti-corrosion protection - hot-dip galvanized.